

RUA

A LOW SEATING DINING CHAIR



RUA IS A LOW SEATING DINING CHAIR
DESIGNED AND MADE BY ME WITH THE
HELP OF THE WORKSHOP STAFF AT THE
NATIONAL INSTITUTE OF DESIGN
AHMEDABAD.

RUA IS A LOW-PROFILE DINING CHAIR
CONCEIVED WITH AN EMPHASIS ON
AFFORDABILITY AND ADAPTABILITY.
INSTEAD OF RELYING ON TRADITIONAL
CONSTRUCTION METHODS SUCH AS
DRILLED JOINTS, GROOVES, OR ATTACHED
UPHOLSTERY,

ITS DESIGN FEATURES A VERSATILE FRAME
THAT ALLOWS USERS THE FREEDOM TO
MODIFY OR PERSONALIZE IT AS DESIRED

THE INTENTION WAS NOT ONLY TO
INTRODUCE A CONCEPTUALLY INNOVATIVE
SOLUTION, BUT ALSO TO EMBODY A
CONTEMPORARY, INDUSTRIAL AESTHETIC
THROUGH A REFINED AND MINIMALIST
DESIGN LANGUAGE..



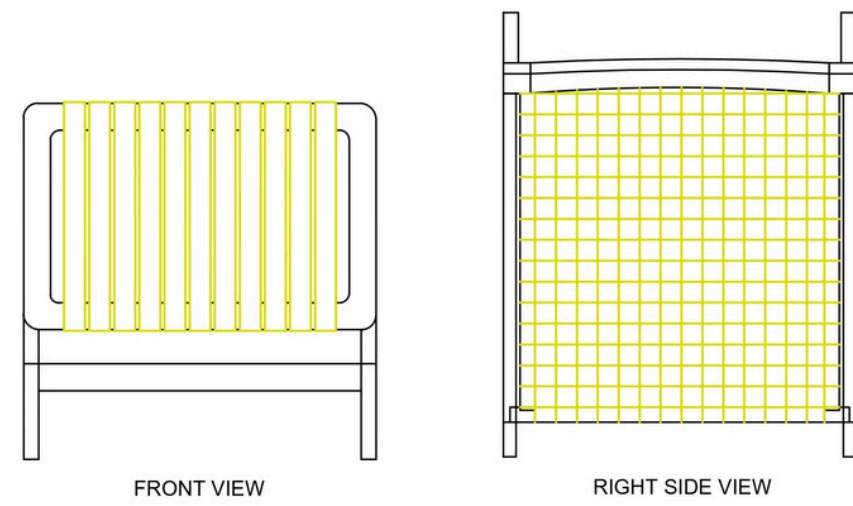

BASKET WEAVE
MATERIAL - COTTON NIWAR PATTI

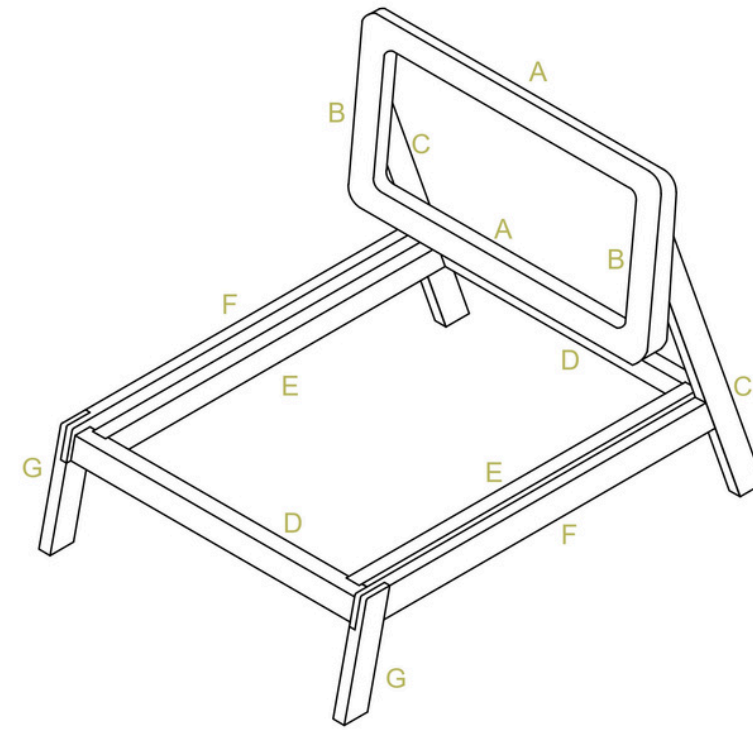

LABEL	MATERIAL	DIMENSIONS		
		L	B	H
A	TEAK WOOD MEMBER - BACKREST FRAME	482	45	25
B	TEAK WOOD MEMBER - BACKREST FRAME	380	45	25
C	TEAK WOOD MEMBER - BACK LEGS	462	45	23
D	TEAK WOOD MEMBER - TIE MEMBER	590	45	25
E	TEAK WOOD MEMBER- WEAVE FRAME	600	45	25
F	TEAK WOOD MEMBER - SIDE MEMBER	700	45	23
G	TEAK WOOD MEMBER- FRONT LEGS	215	45	23

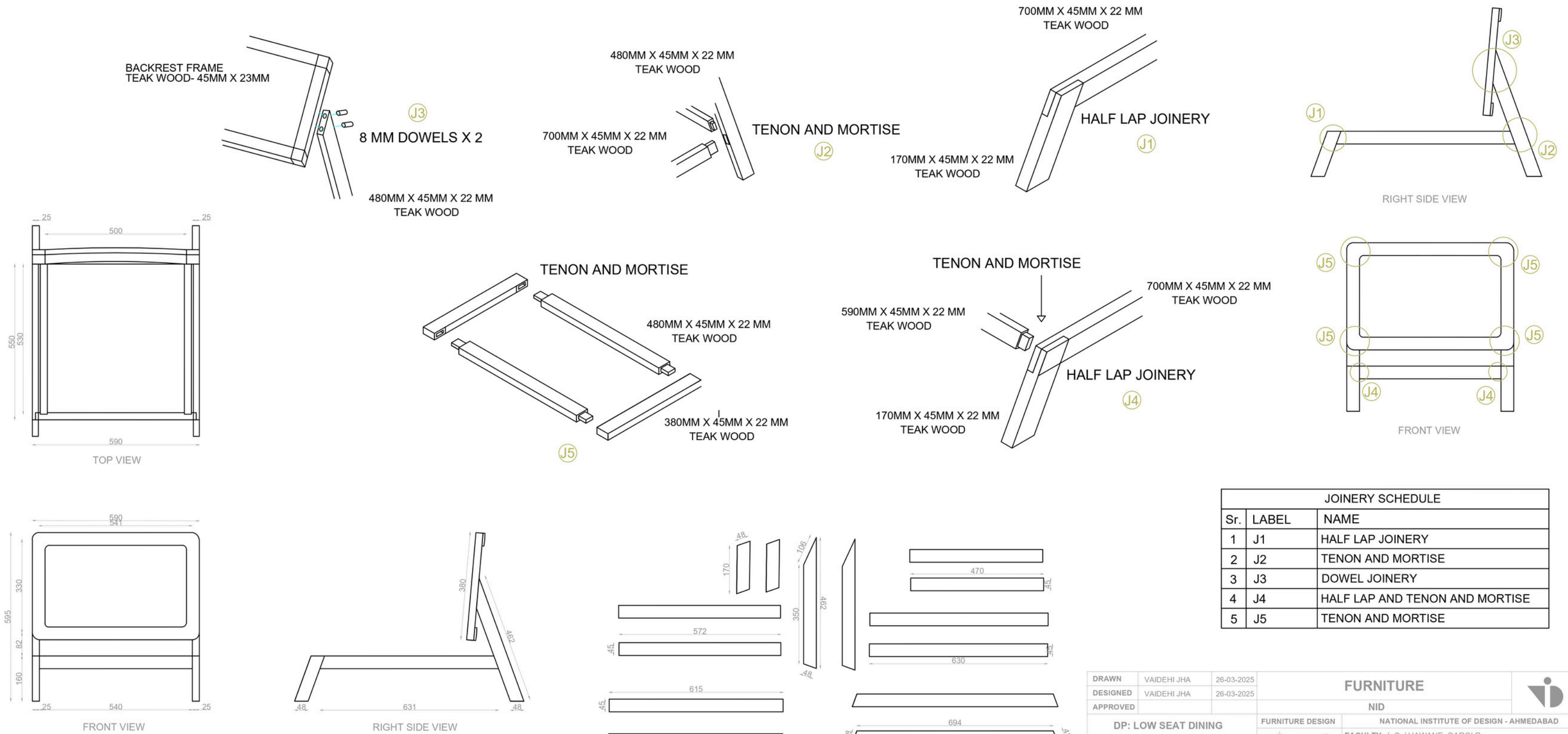

JOINERY SCHEDULE		
Sr.	LABEL	NAME
1	J1	HALF LAP JOINERY
2	J2	TENON AND MORTISE
3	J3	DOWEL JOINERY
4	J4	HALF LAP AND TENON AND MORTISE
5	J5	TENON AND MORTISE

DRAWN	VAIDEHI JHA	26-03-2025	FURNITURE		NID
DESIGNED	VAIDEHI JHA	26-03-2025			
APPROVED			NATIONAL INSTITUTE OF DESIGN - AHMEDABAD		
DP: LOW SEAT DINING			FURNITURE DESIGN		
GENERAL TOLERANCES			FACULTY: L.C. UJAWANE, GARGI R.		
ALL DIMENSIONS ARE IN MM.			SCALE: 1:2 SHEET 01 OF 01 SHEETS COURSE:		
			DO NOT SCALE THE DRAWING DESIGN PROJECT-1		

PROCESS PICTURES



PROCESS PICTURES - DYEING OF COTTON PATTI



TEAK WOOD



BASKET WEAVE

MATTE FINISH LACQUER
ROSEWOOD FINISH

COTTON NIWAR PATTI