

## Anugu - The Wooden Bench

**ಅಣುಗು** (Aṇugu)(Kannada)

*noun*

fondness; affection;  
warm feelings; love.



## The Brief

**A bench**, that is not just for sitting but a furniture that blends in with any space and serves multiple purposes. It also looks stylish and at the same time provides comfort to the users in a domestic set-up.

## Key Elements

**Portable**

**Sleek**

**Comfortable**

**Two seater**

**Multiple textures  
blending  
together**

**Can be placed in  
various  
places within  
a household**



## Furniture Typology **An Interior Bench**

**Contemporary design with the use of Minimal and sustainable materials.**

**Mood Board**

## Concept

Minimal usage of materials, and repetition of lines and shapes while blending multiple textures effortlessly.

This Contemporary bench is designed with multiple turned wood members coming together as one.

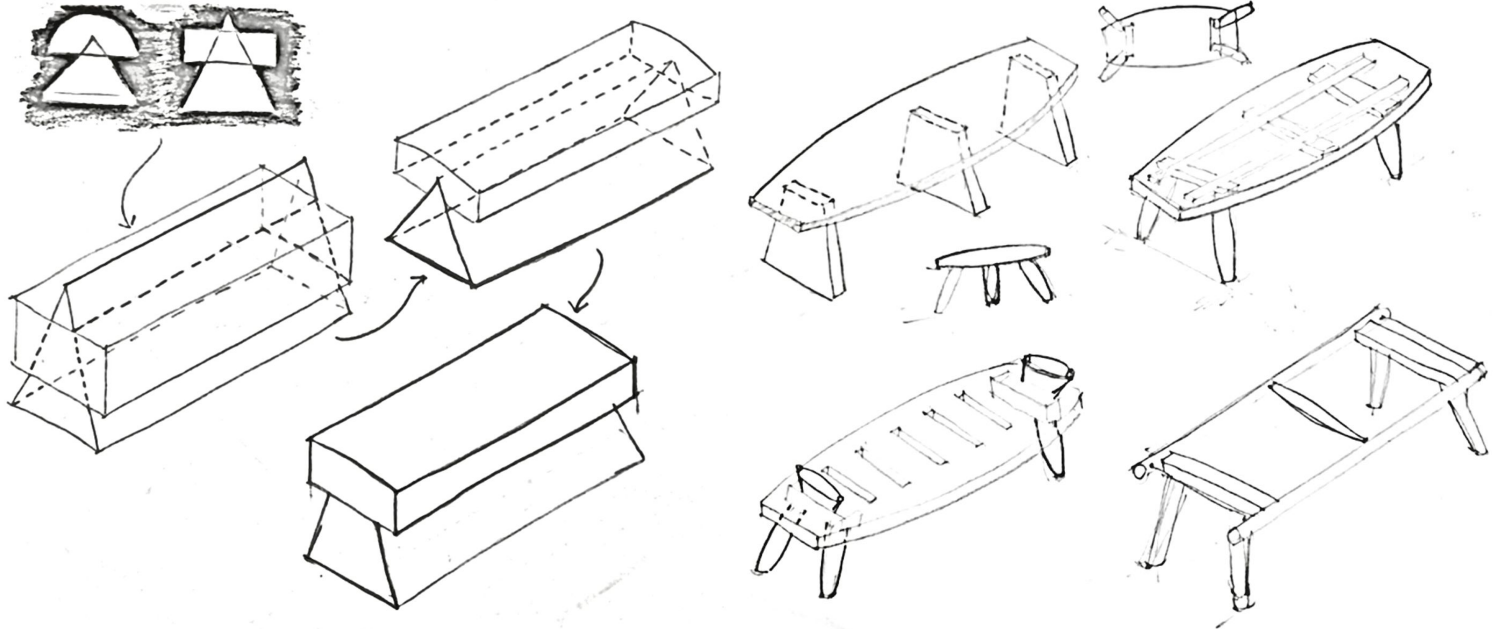



# Materials

## Material

1. Teak wood
2. Cotton Ropes, 3mm dia

## Reason

1. Teak's property to withstand harsh weather conditions, and its re
2. Cotton is a natural material which has a really strong grip compared to synthetic fibres



**Scale model - 1:5**



**Scale model - 1:5**



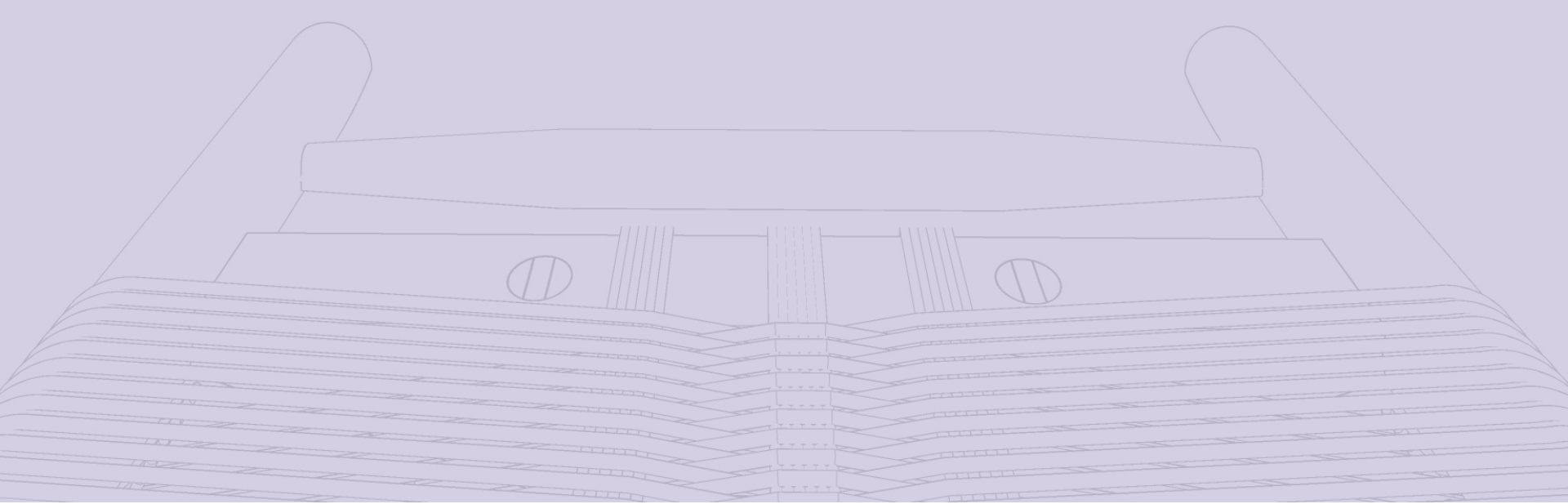

## The Renders













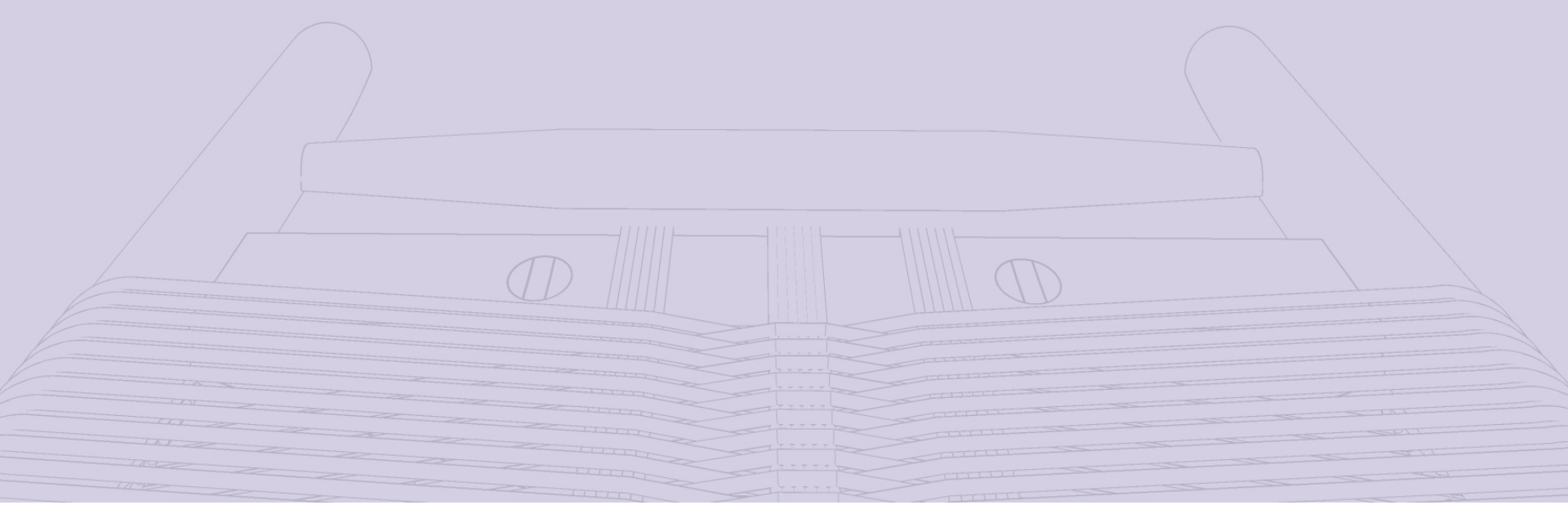

## The Process

# The Process









Drilling holes at 18 degrees



Fit test









Mortising the main member



Sanding



Leveling the legs



Components





Before Lacquer



During Lacquer



The structure after  
melamine coat



Untangling the knots



Weaving

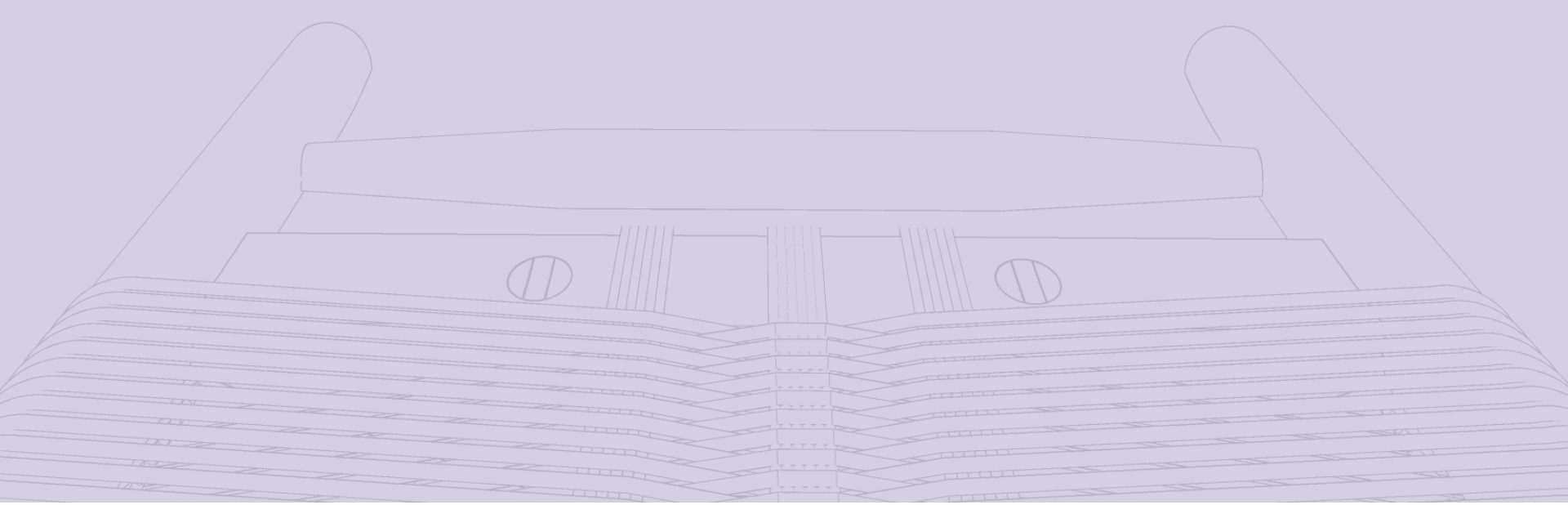

## Prototype Photos







































---

**Thank You**