

Savari - The Rocker

Concept Sketches

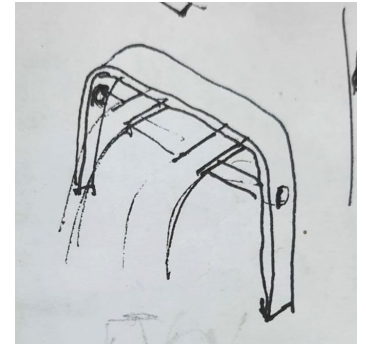

Concept Sketches

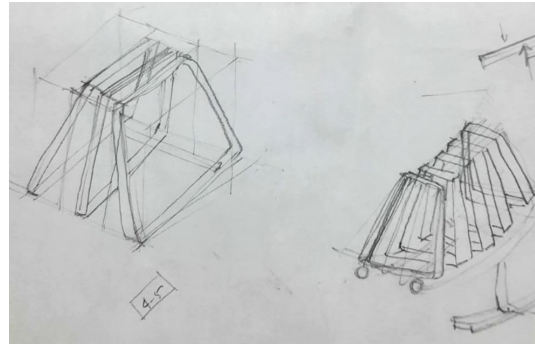
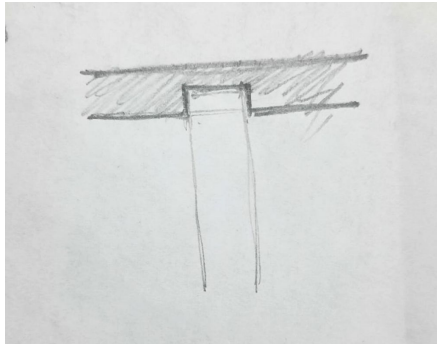
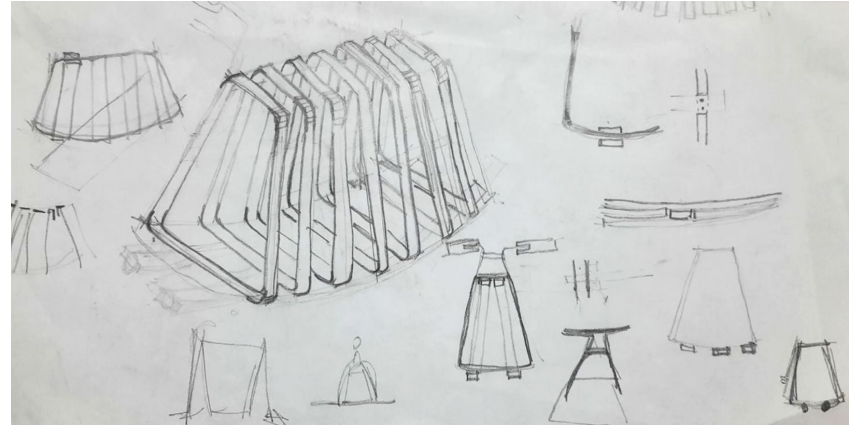
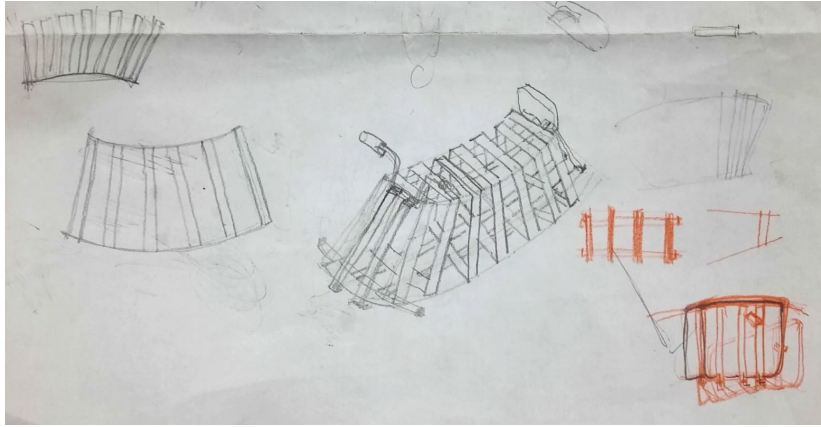
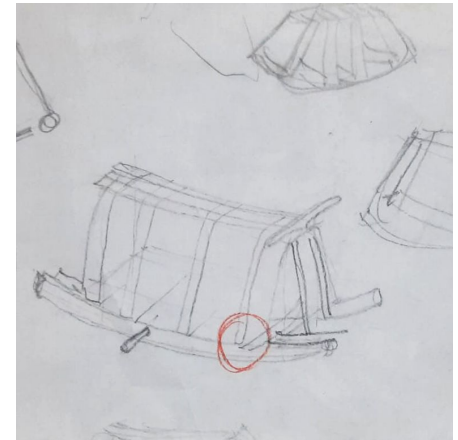
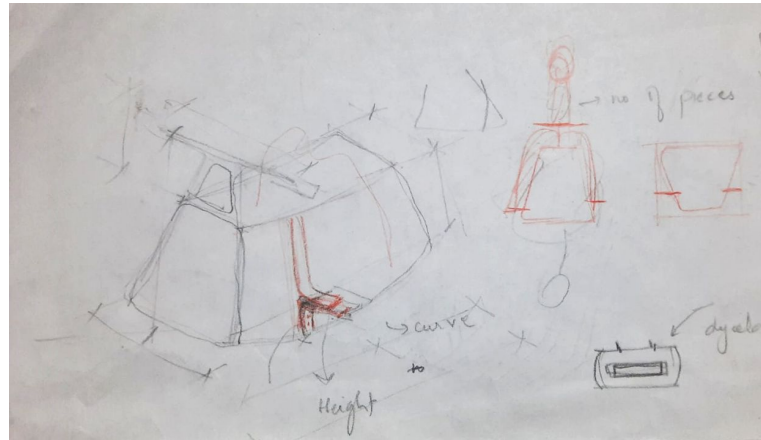
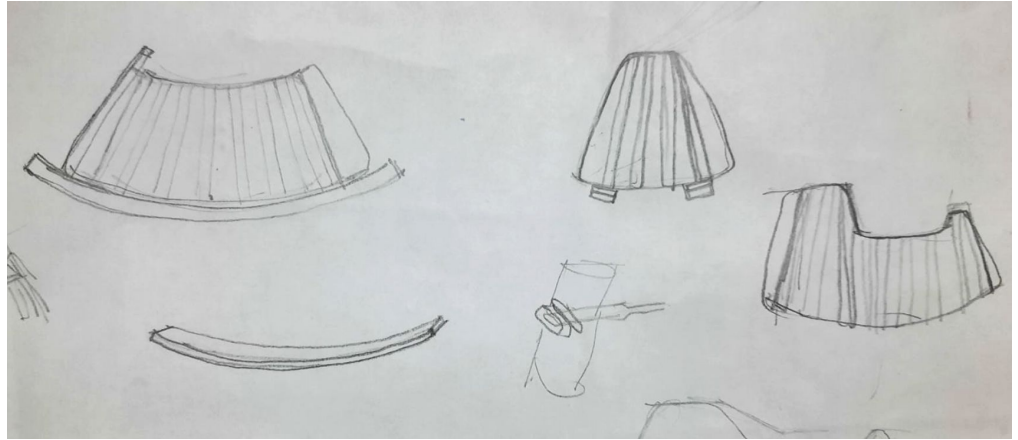

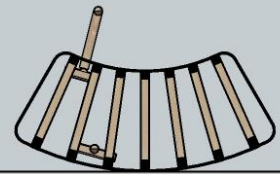

Initial Iterations

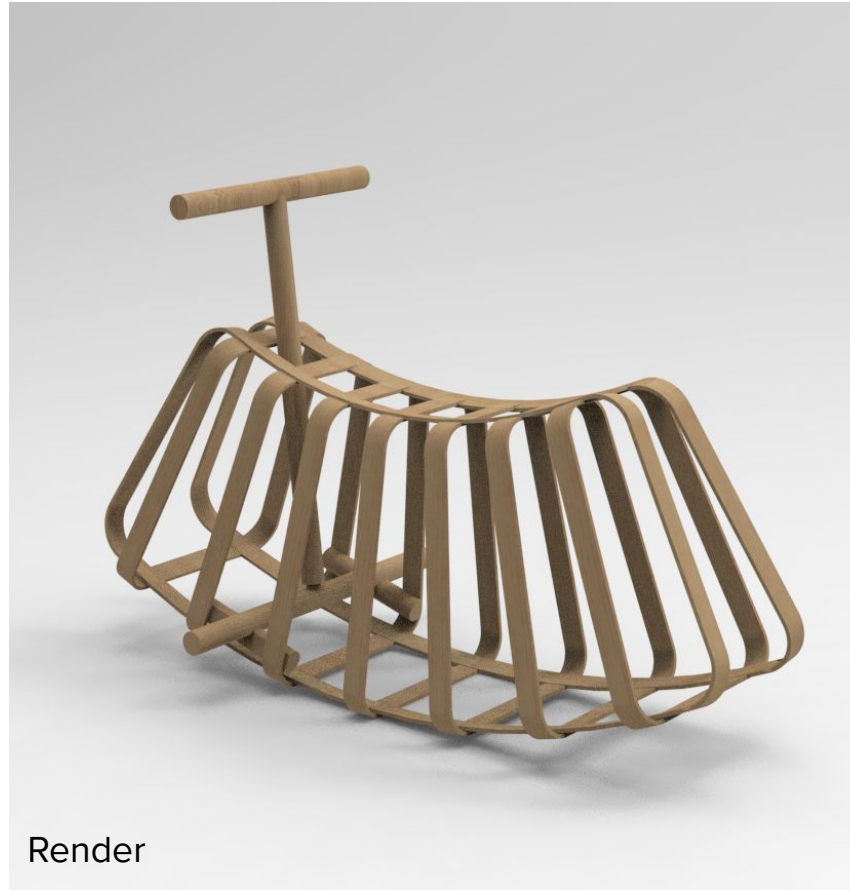

Render



Renders



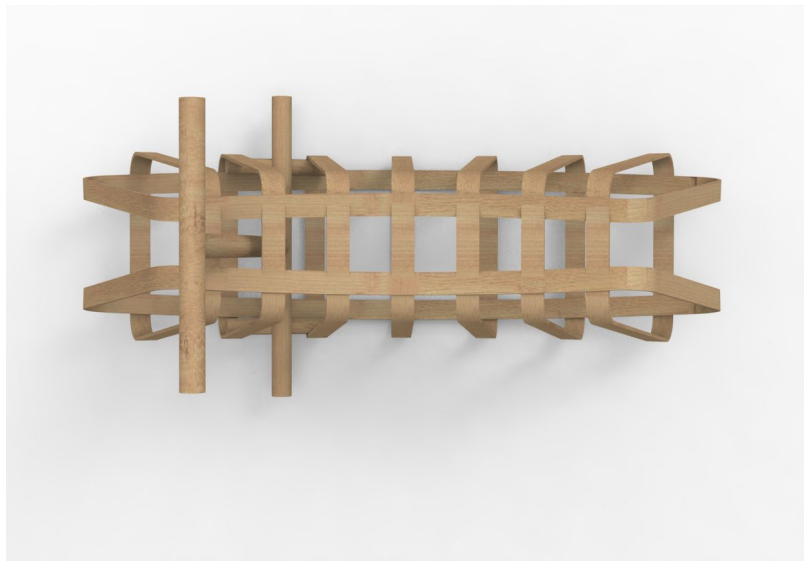

Render

The Process Pictures



Making The jig, Heat Bending process of all the loops, and Laminating process of all longer members



Heat Bending to expand the size of the smaller loops due to the shrinkage, and cleaning the burnt parts of the loops



Finishing the Laminated loops,
Removing Araldite, Making groove
cuts for the lap joints, Sanding the
skin off from the strips



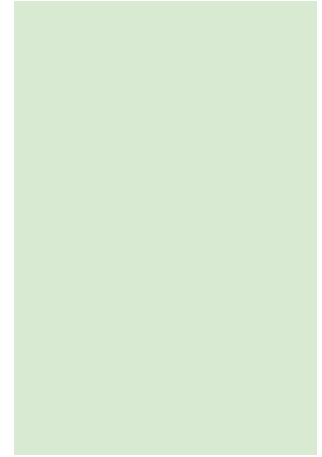



Fixing the smaller loop to the longer loops using lap joints from both ends to the center





Cleaning araldite marks, and fixing the support for the legrest

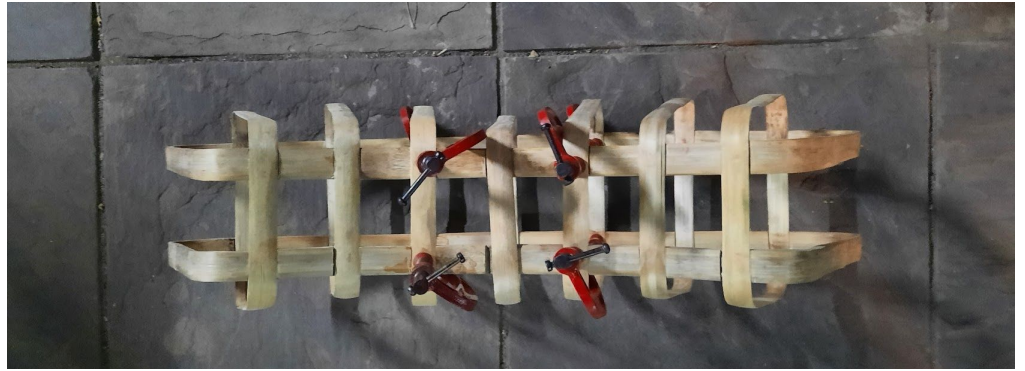



Shaping of the spine to fix the handle



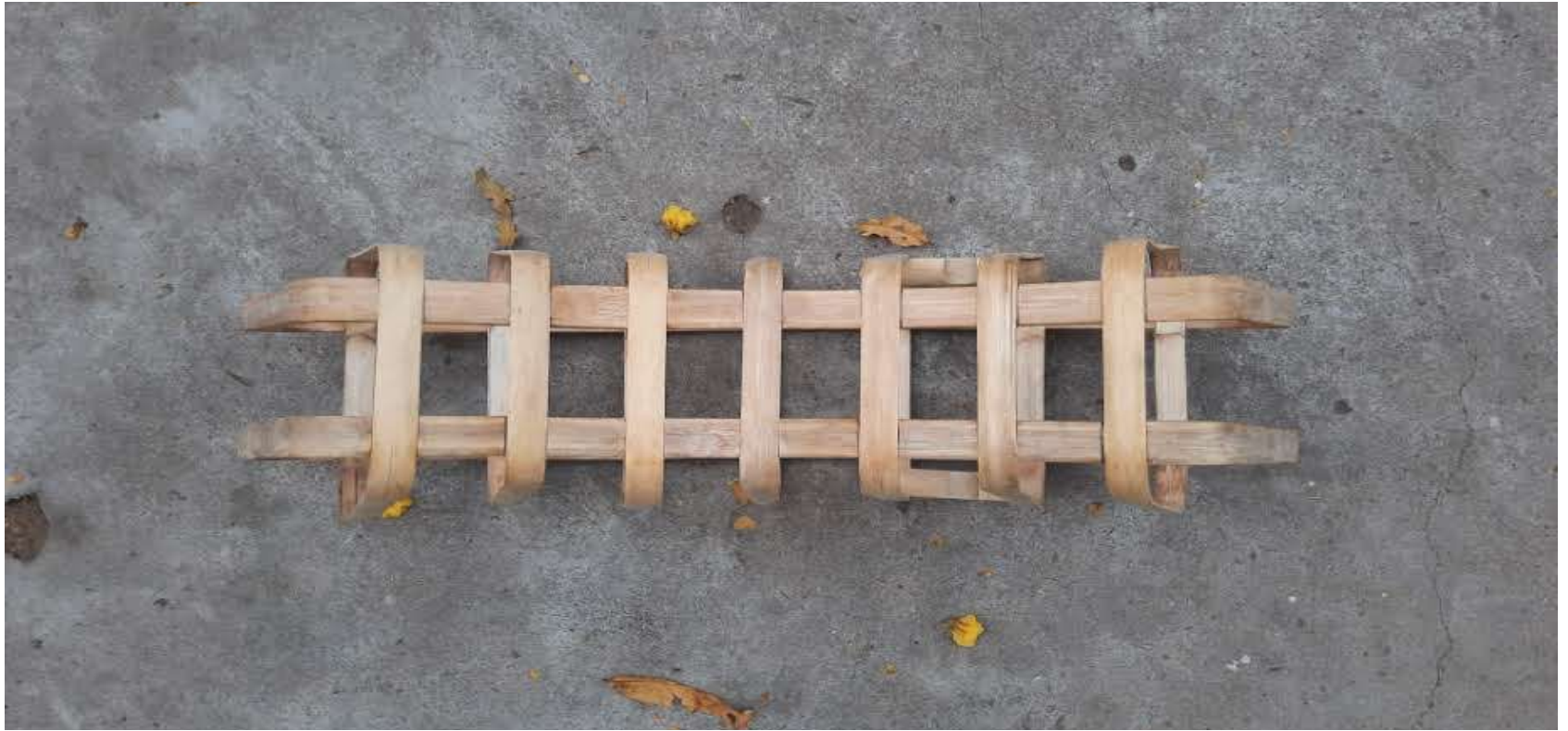

Work in Progress

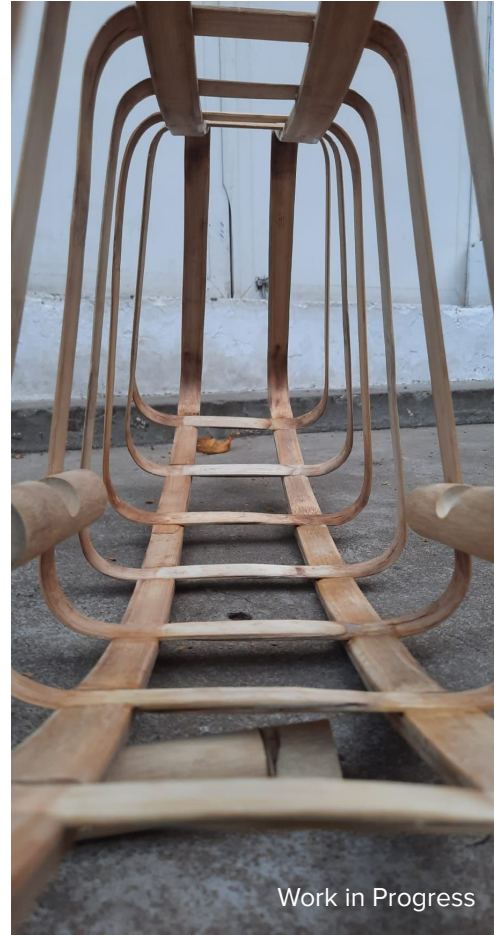

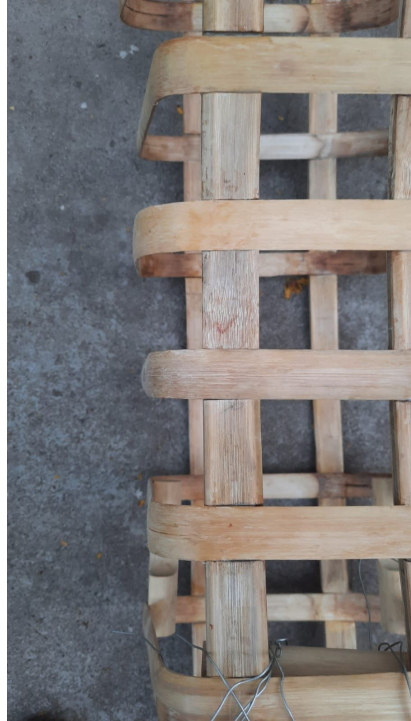
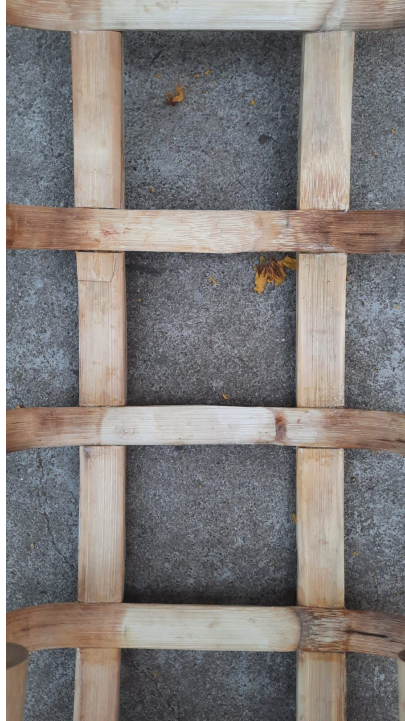
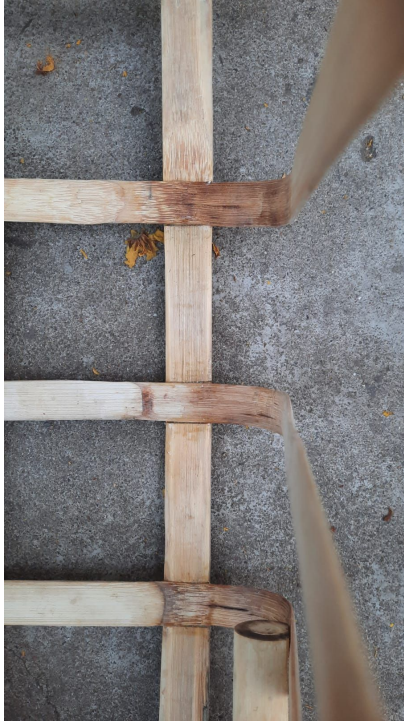



Work in Progress





The Final Prototype







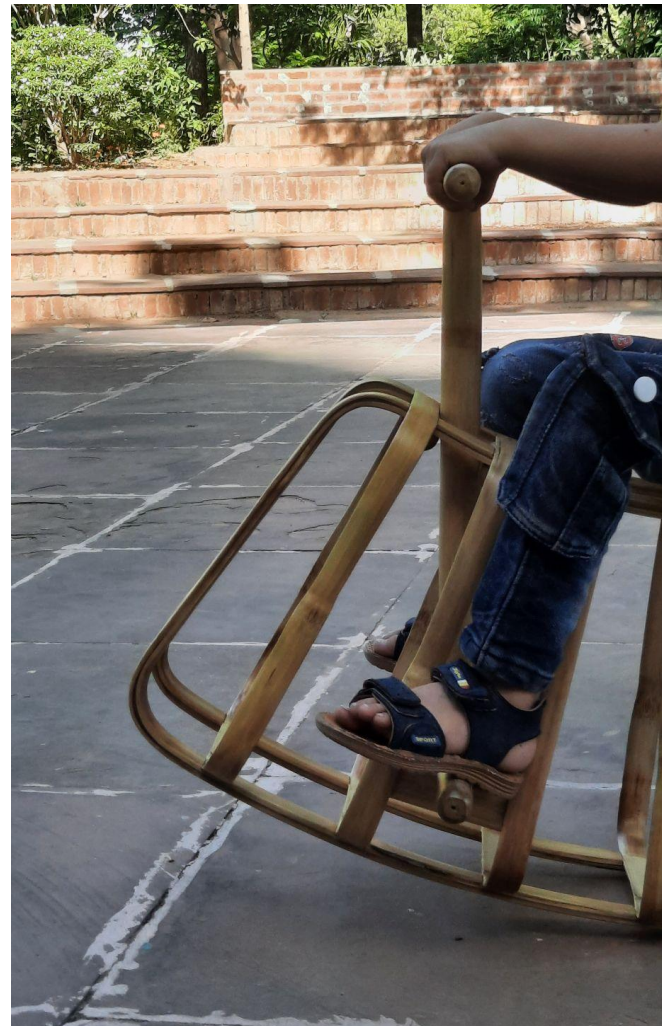



Thank You