

BAMBOO RADIANCE

Lighting Range

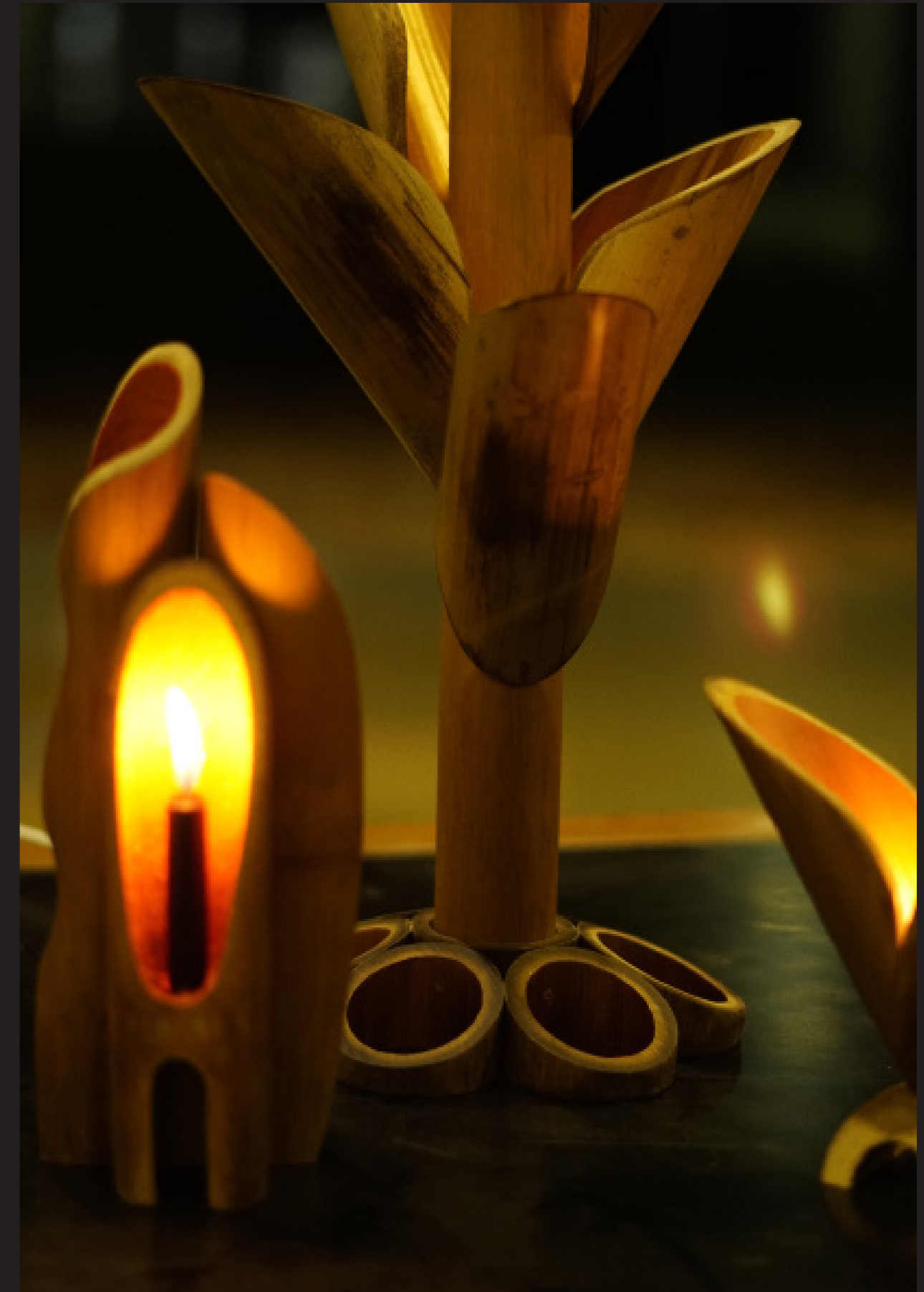

CONTENTS

01



Bamboo Lighting range

- Product 1
- Product 2
- Product 3

02



Material and Form exploration

MATERIAL USED :

- Bamboo
- Sand

Rationale behind using these materials :

- BAMBOO
- Bamboo was selected for the Petal Structures Lighting project due to its exceptional sustainability and minimal environmental impact. It grows rapidly, requires no pesticides, and helps combat climate change by absorbing more carbon dioxide than trees. Bamboo is versatile and durable, with a high strength-to-weight ratio, making it ideal for both structural and decorative elements. Its natural aesthetic adds elegance and tranquility to the lighting fixtures. Additionally, using bamboo supports local economies and traditional craftsmanship, aligning with the project's commitment to eco-friendly and beautiful design.
- SAND
- Using sand as a protective coating for candle holders is a sustainable choice due to its natural abundance and availability, reducing the need for extensive resource extraction. Sand is non-toxic and inert, ensuring safety and environmental friendliness when exposed to flame. Its flame-resistant properties enhance the durability and longevity of the candle holders, reducing the need for frequent re-

01 BAMBOO LIGHTING

Brief :

Making a range of 3 product accessories for a particular space

A Bamboo Lighting Collection curated specifically for the *living room space* which includes a *bed-side lamp, candle holder and a tea light candle holder*. The warm tones and unique textures of bamboo seamlessly integrate with various interior styles, adding a touch of nature to our home. Also small details like *sand coating and metal base on candle holder* not only brings the aesthetic appeal but also serves the purpose of protecting the piece.



INSPIRATION BOARD



I took Bamboo Leaves as my inspiration for deriving the petal structures. These petal-shaped structures feature fluid, organic curves reminiscent of petals.



BEDSIDE LAMP

01 A

A bedside lamp for the living room or bedroom which adds a touch of comfort to the space. We can *use it as a night light in a dim setting* or to read a book in bed. It works on the concept of *diffused lighting* rather than a direct light to provide that sense of comfort and calmness in your little space that you own.

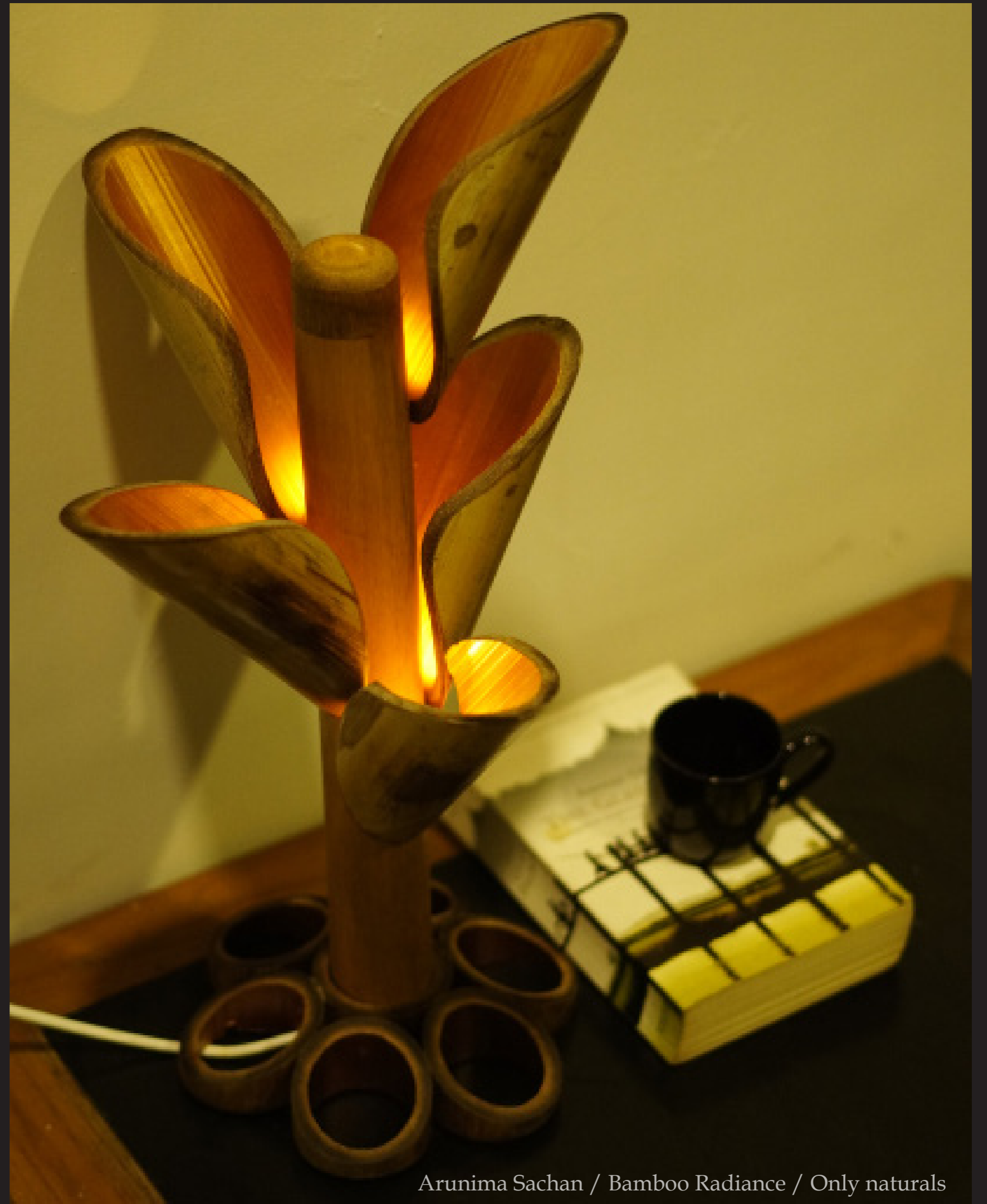

Arunima Sachan / Bamboo Radiance / Only naturals

IDEATIONS

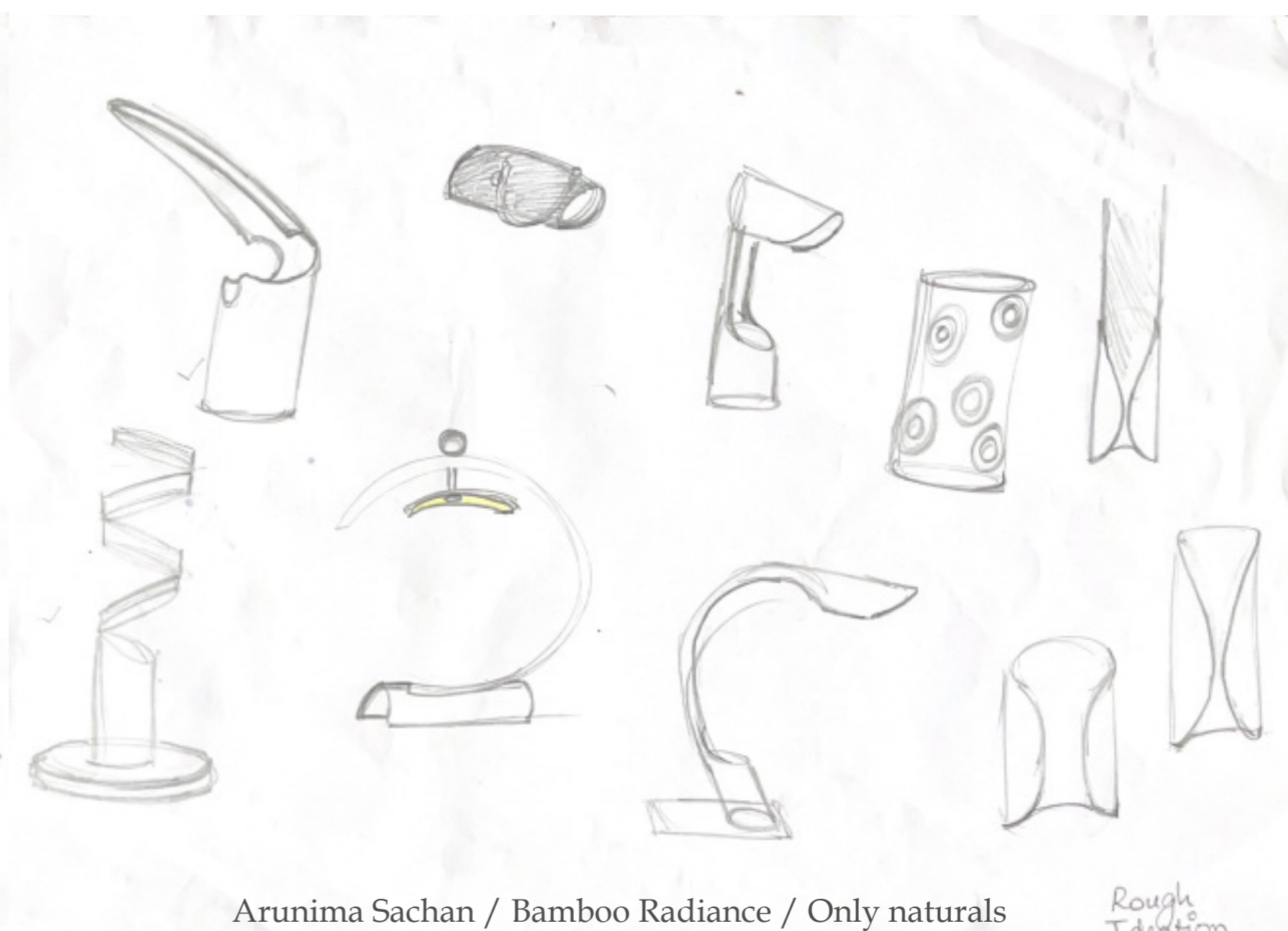
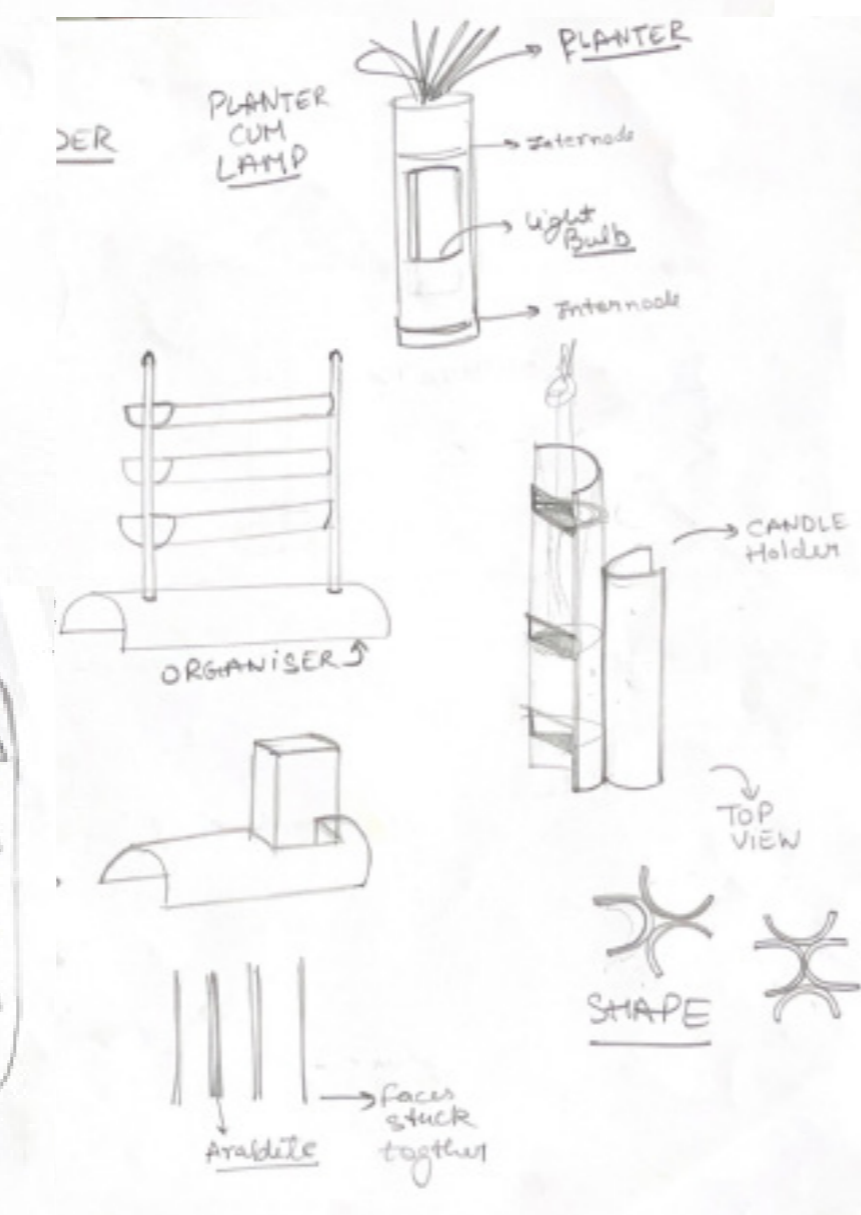
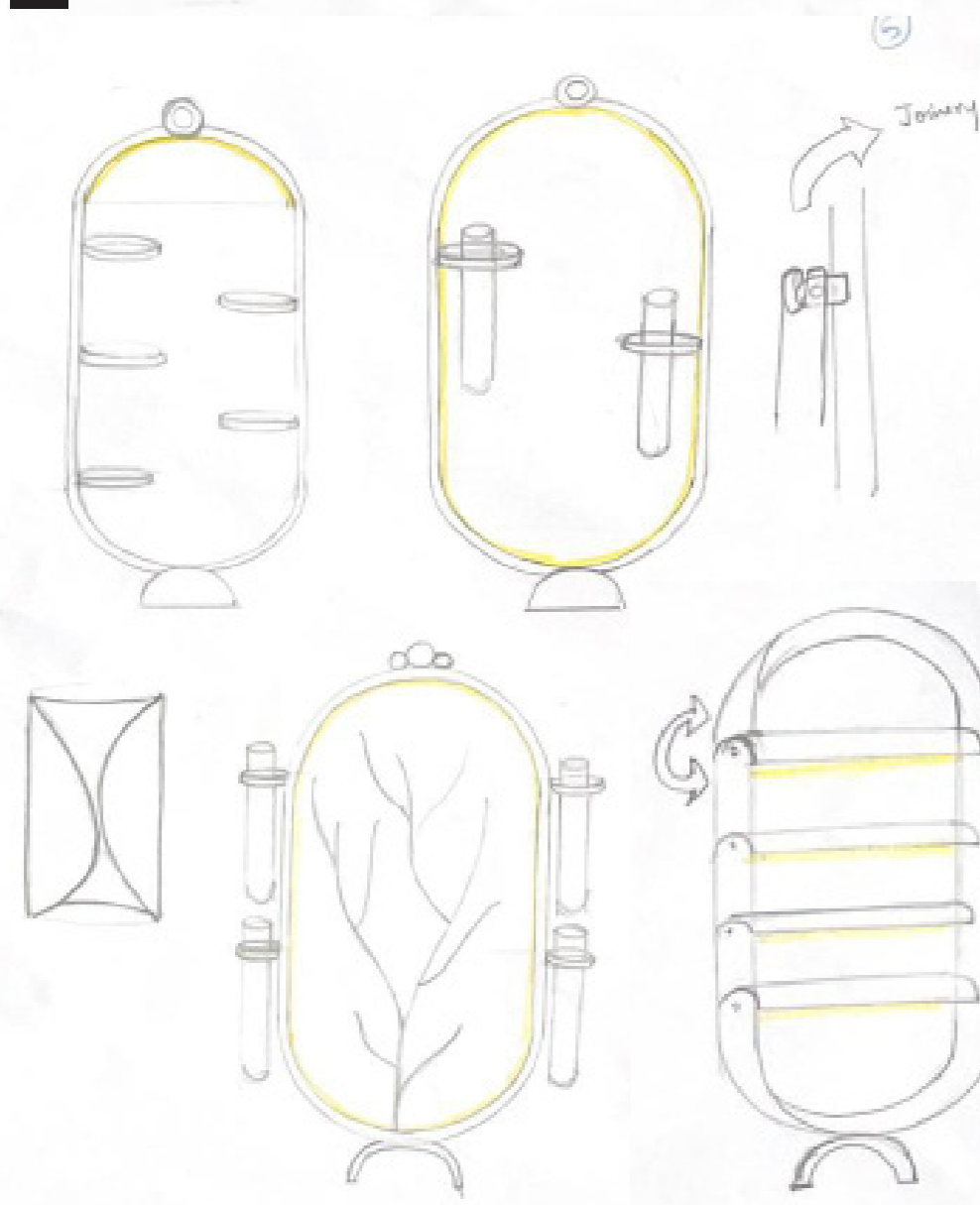
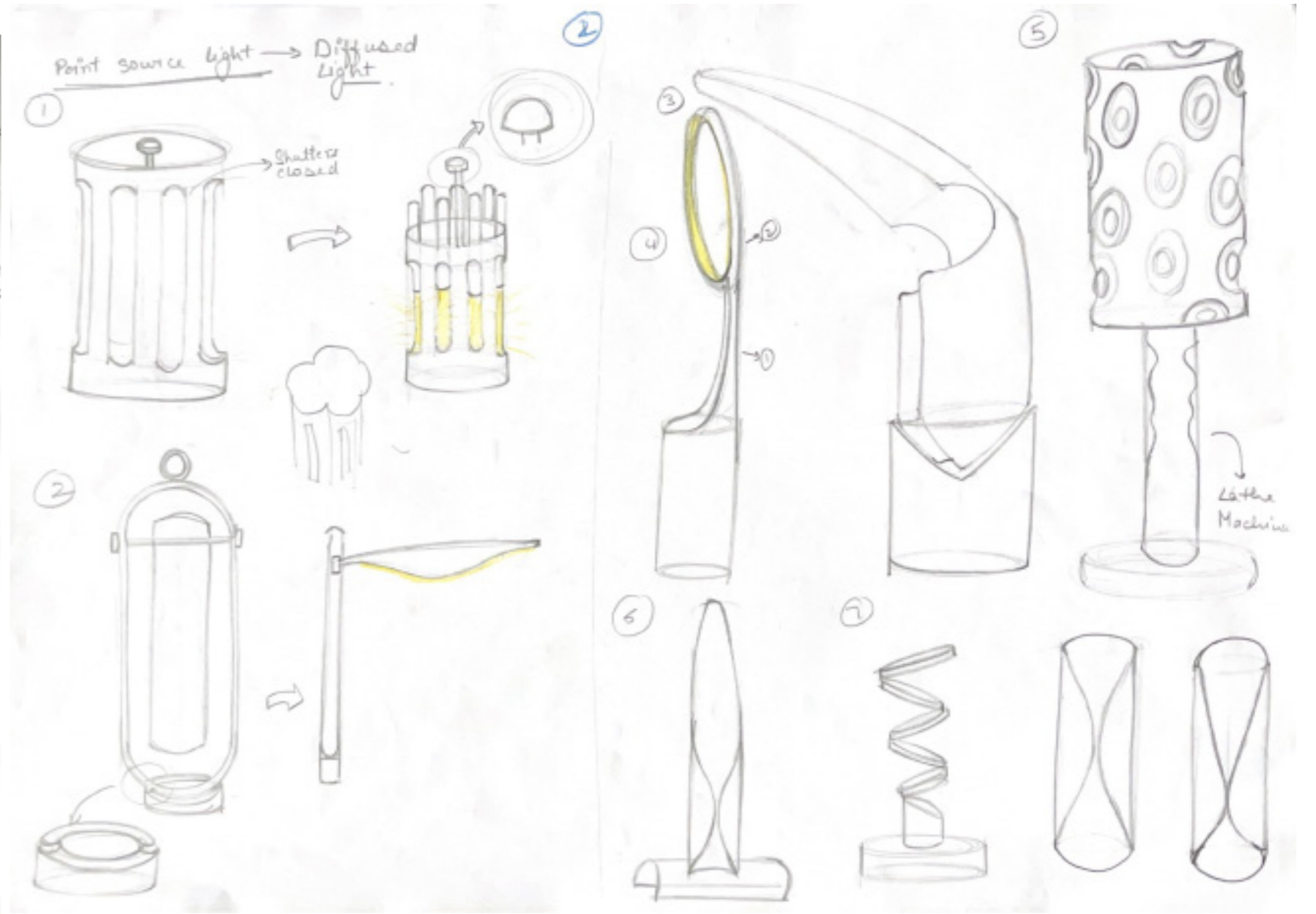
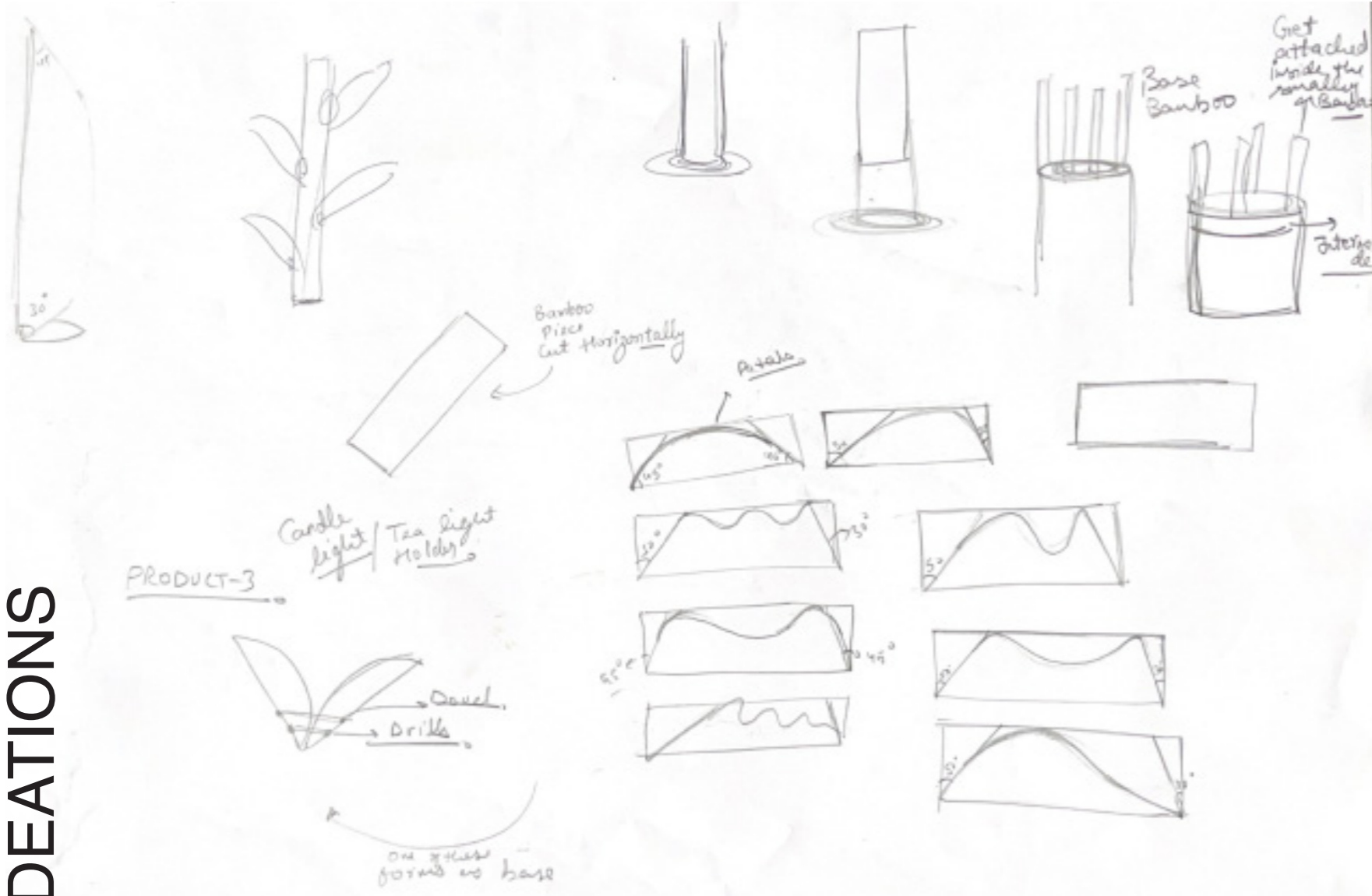

IDEATIONS

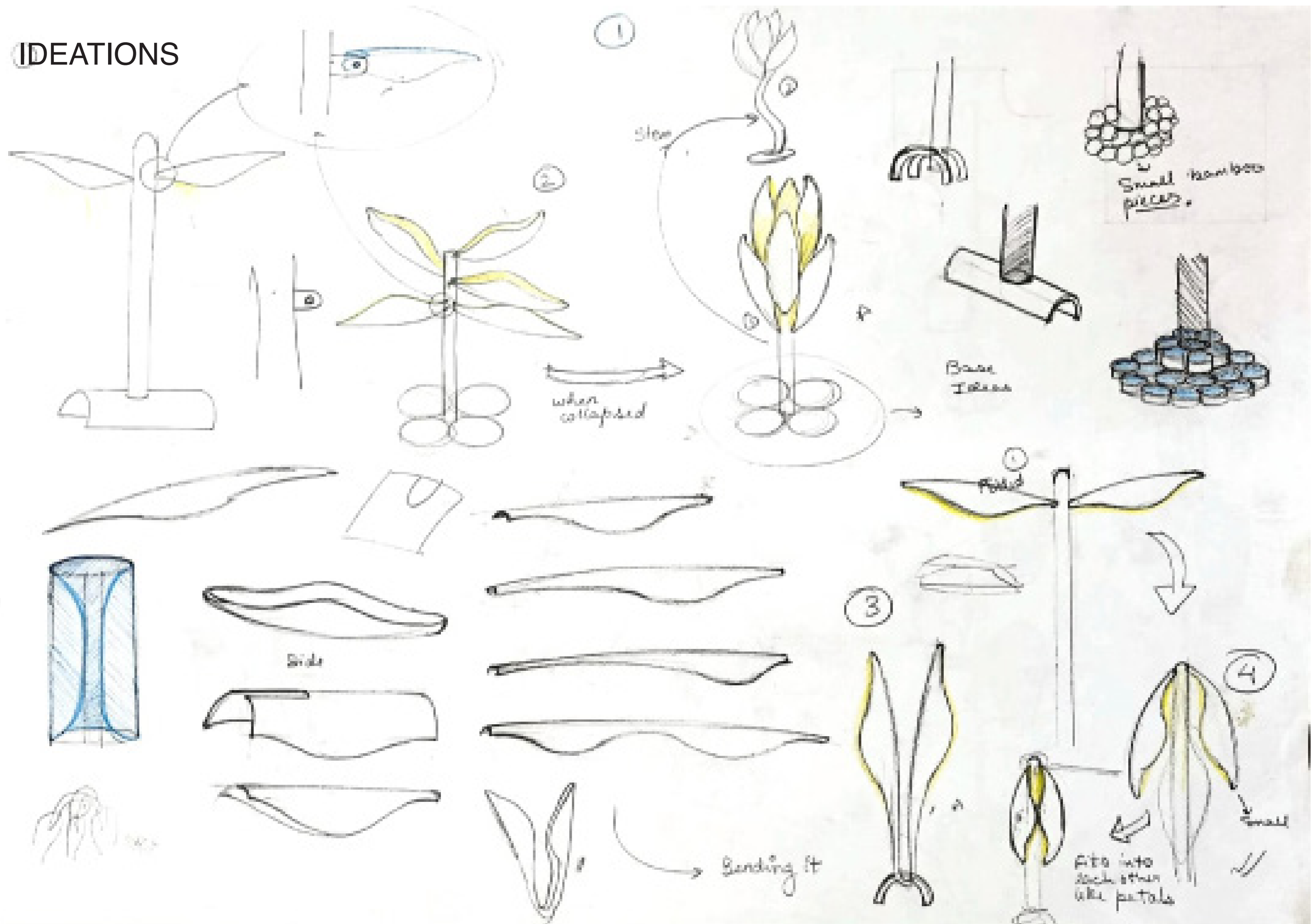

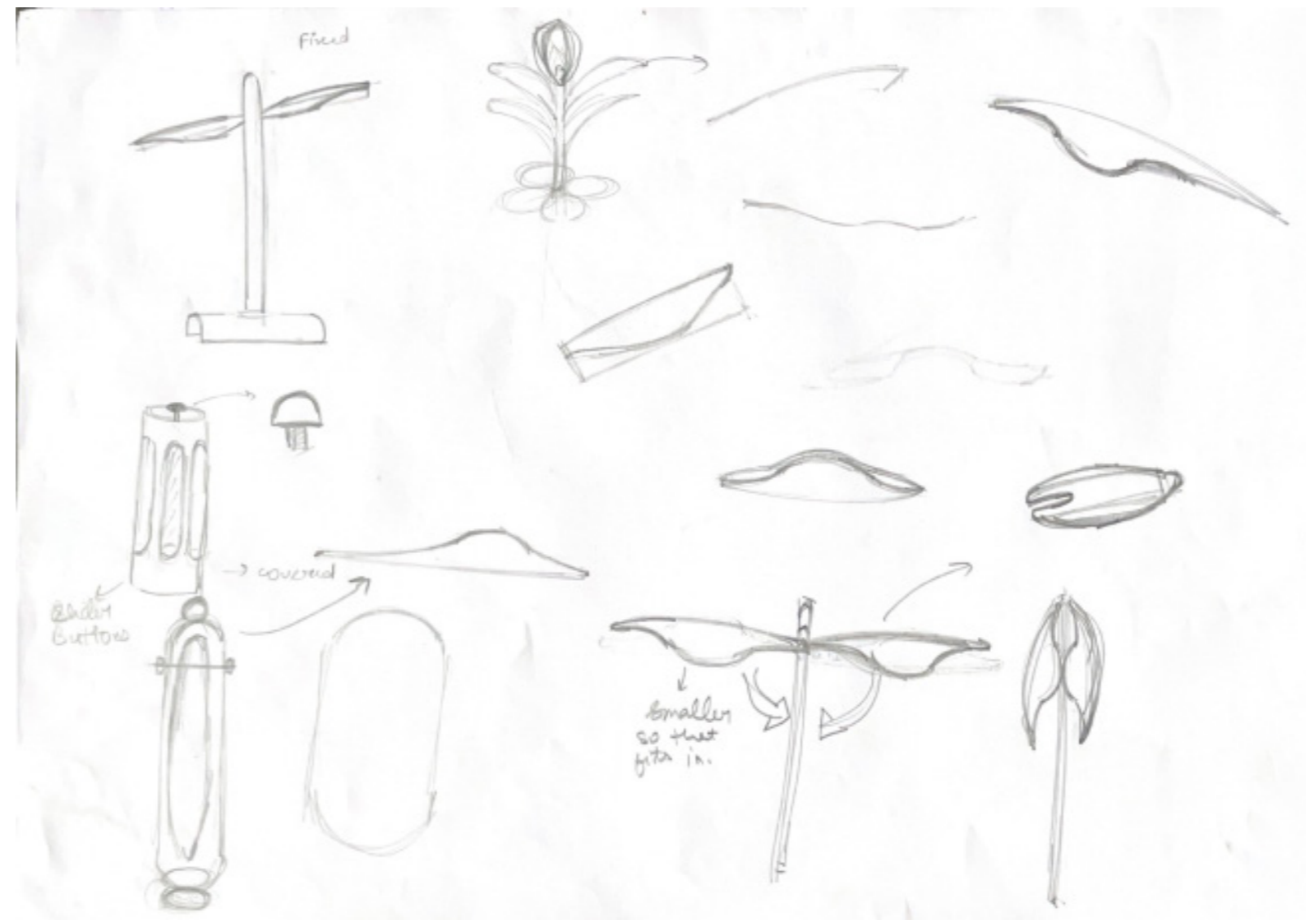
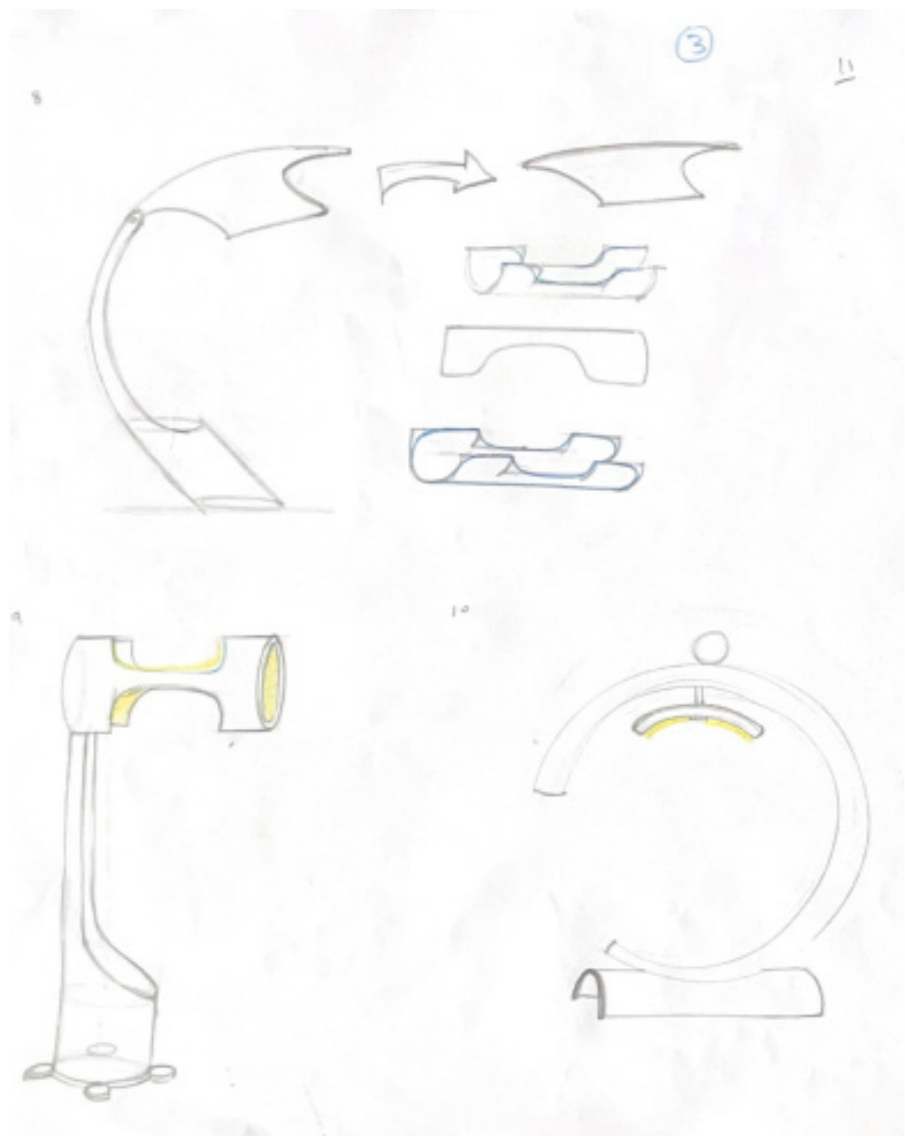

Final Design

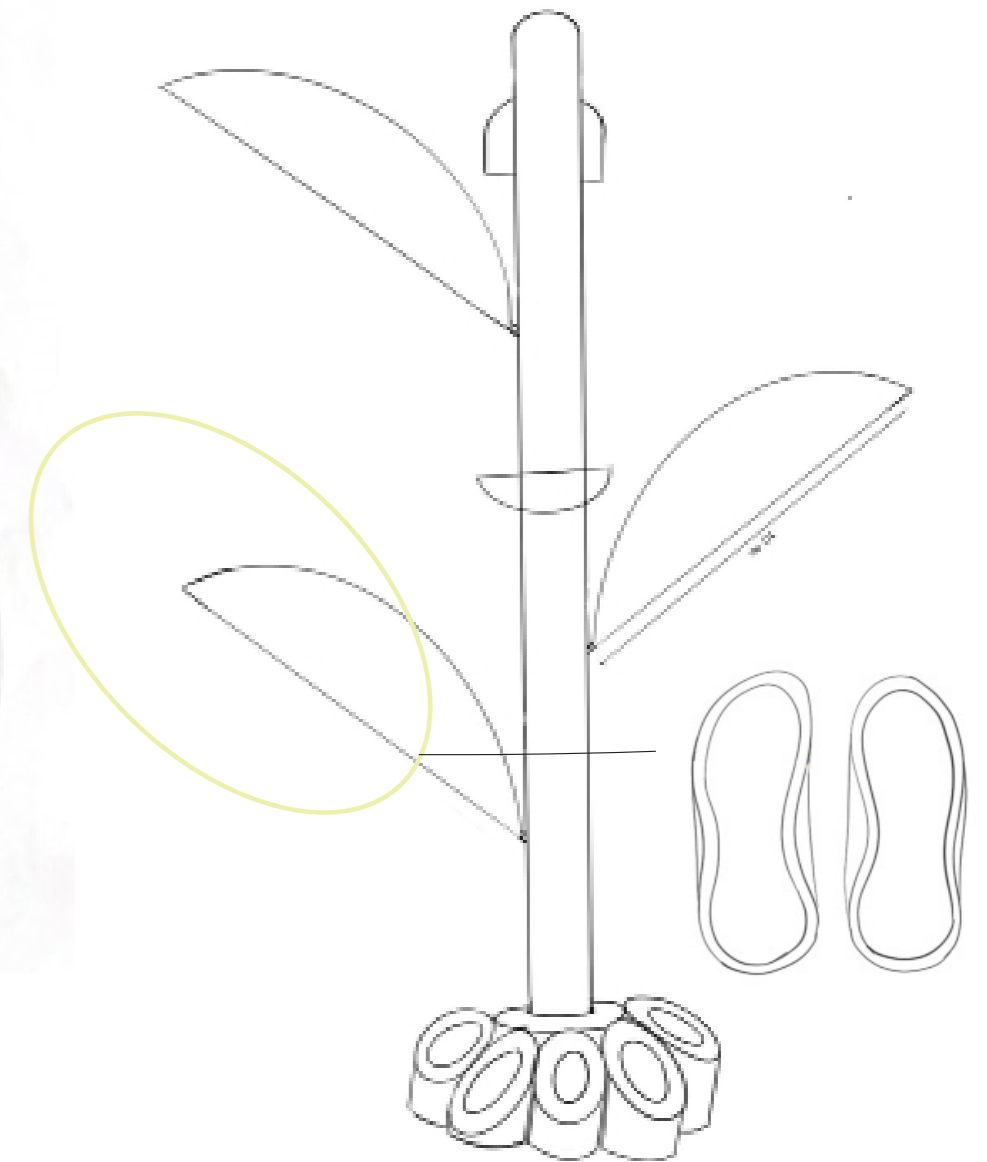
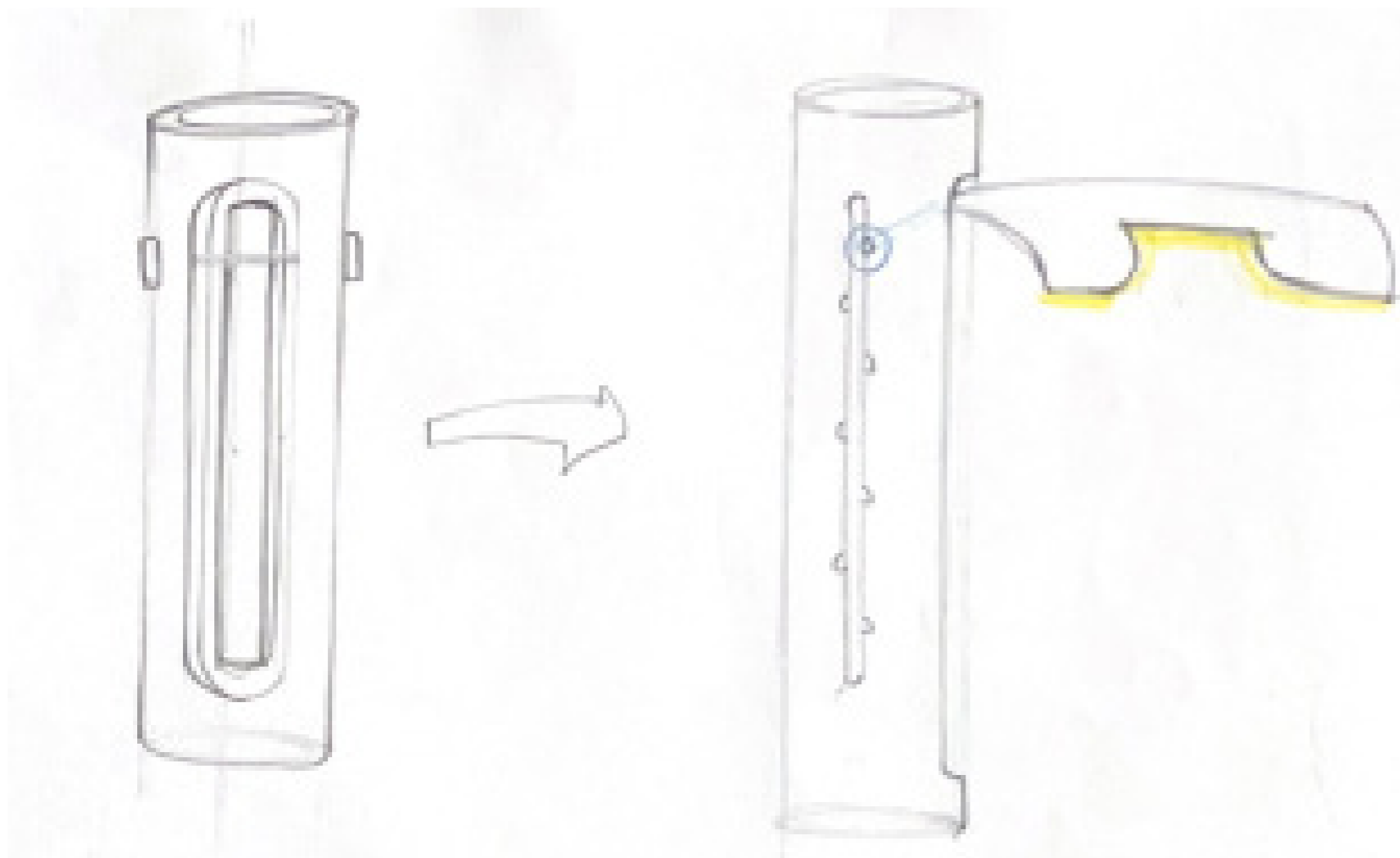
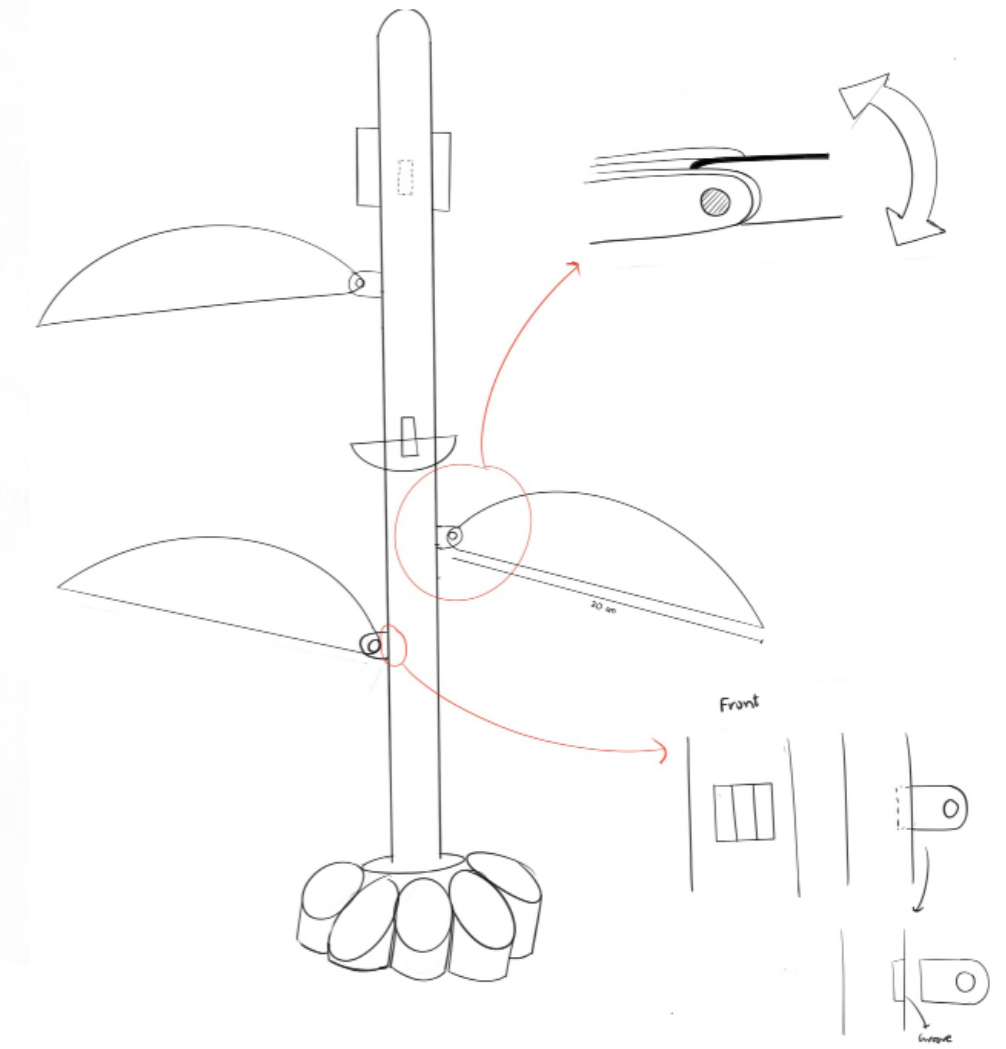

Isometric View

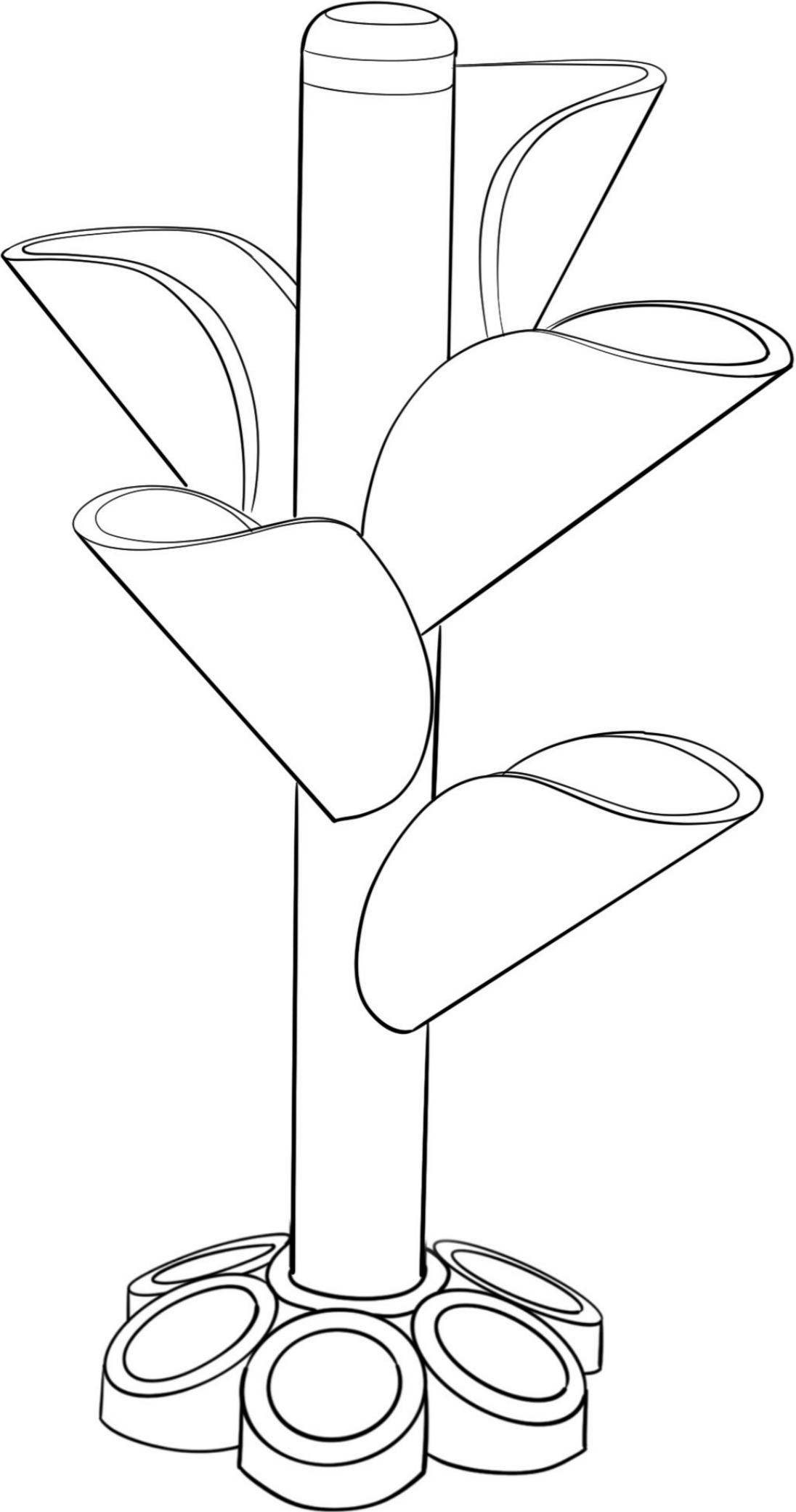

TECHNICAL SPECIFICATION

Material - Bamboo
Finish - Lacquer

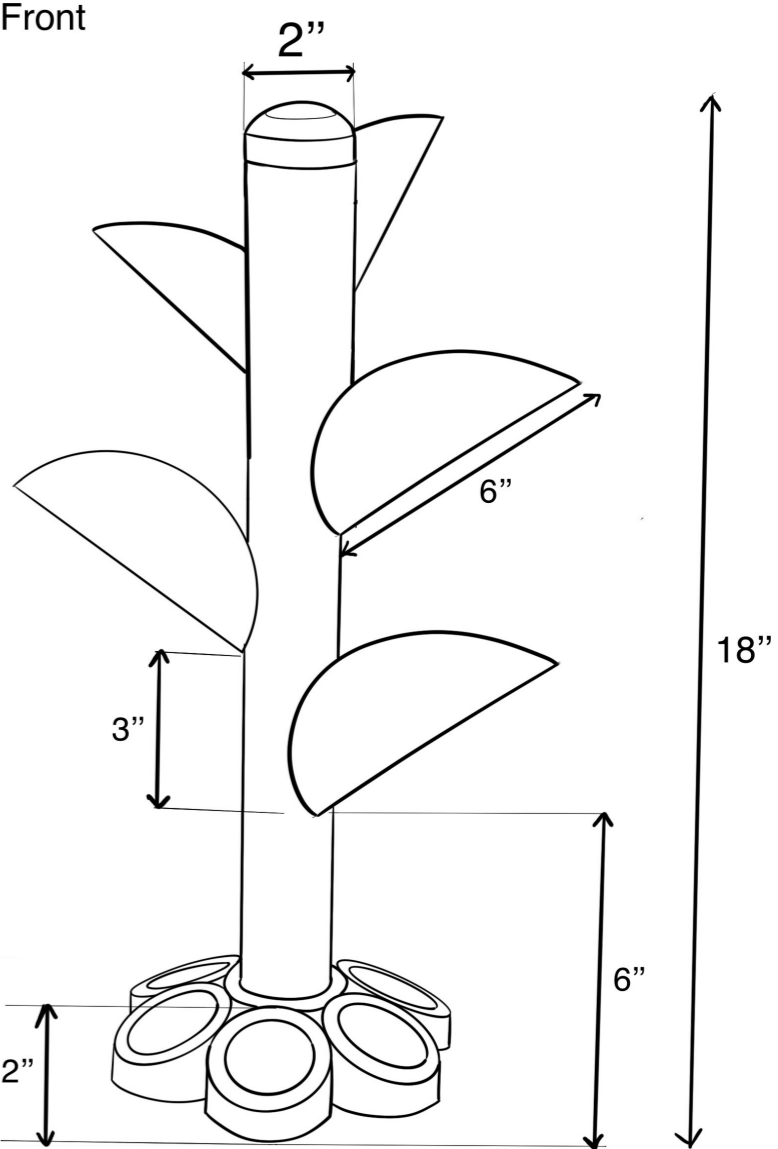

Top

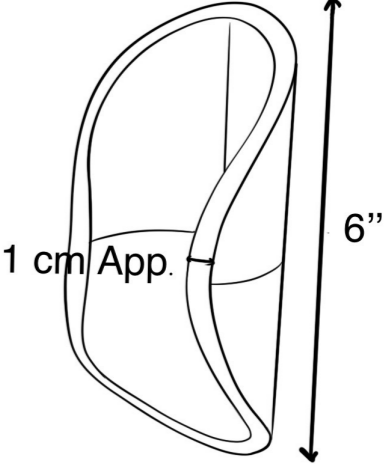
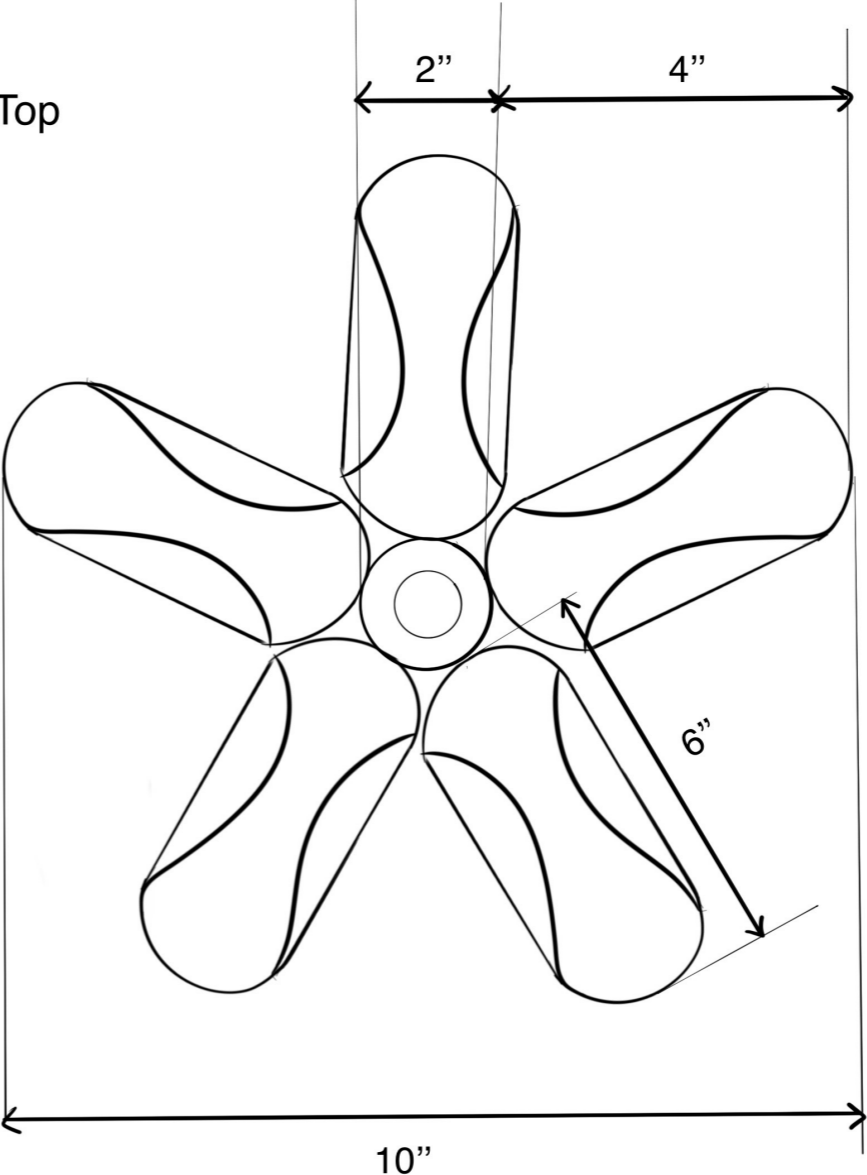

About product :

- **Reflected light** from the petal structures gives a soothing dim lighting.
- The petal structures are fixed onto the stem with dowels so they can be detached for conversion into a direct source lighting.
- Also the entire upper structure can be detached from the base for **easy maintenance**.



Holes drilled diagonally in a grid



Manipulation of the edges to give a curvilinear form.

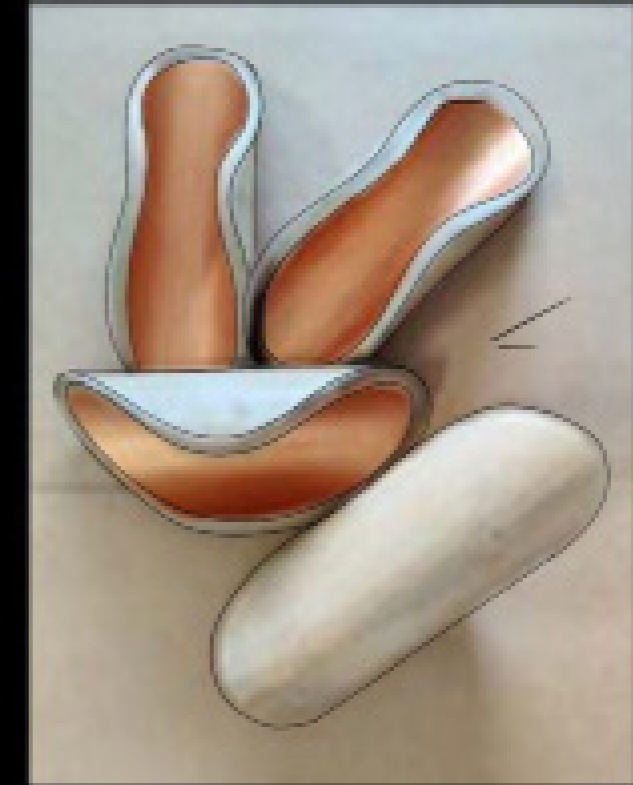

Painting the inner surface with acrylic to make it reflective.

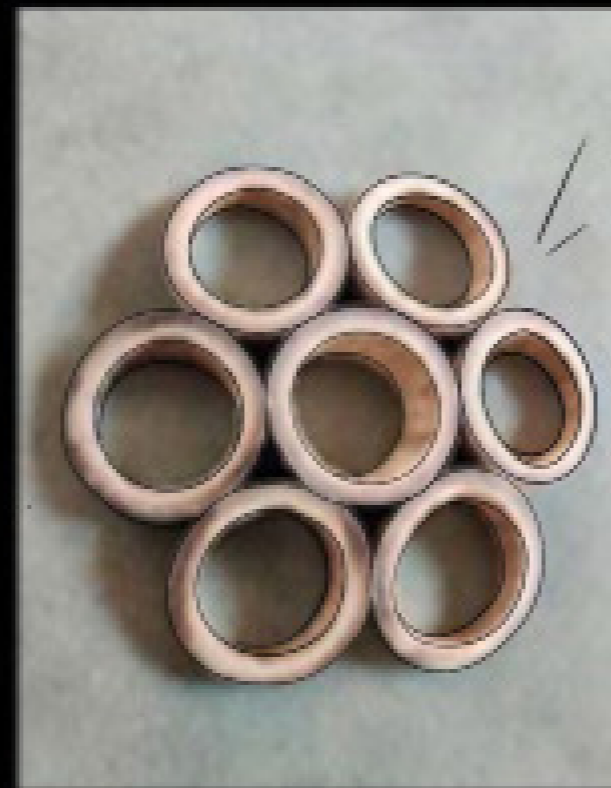

Leveling the base structure after joining them together.



Fixing Petal structures using dowel.



Wiring and fixing of light in the stem structure



Arunima Sachan / Bamboo Radiance / Only naturals

CANDLE HOLDER

01 B

A combined three piece candle holder with all the holders following a form family. Making use of the internodes of bamboo, **platforms** have been created **at different heights** for the candles to be kept. As bamboo is a flammable material a **layer of dyed sand has been added on the interior surface** which also adds to an interesting texture. Also the warm and vibrant colour of the sand adds a colour contrast to the subtle tone of bamboo and also adds to the intensity of light.



About product :

- All three **pieces of candle holder can be separated to be used as a single unit.**
- The base is at different heights for varied sizes of candles and the base contains a metal plate for **easy maintenance** .
- The orange dyed sand coating not only provides **protection against fire** but even offers a tactile and visually appealing tex-



Splitting with an internode to get the base for candles to be held.



Making a form family



Assembling them using dowels.



Applying sand on the inner surface.



Finishing outer edges and surfaces.

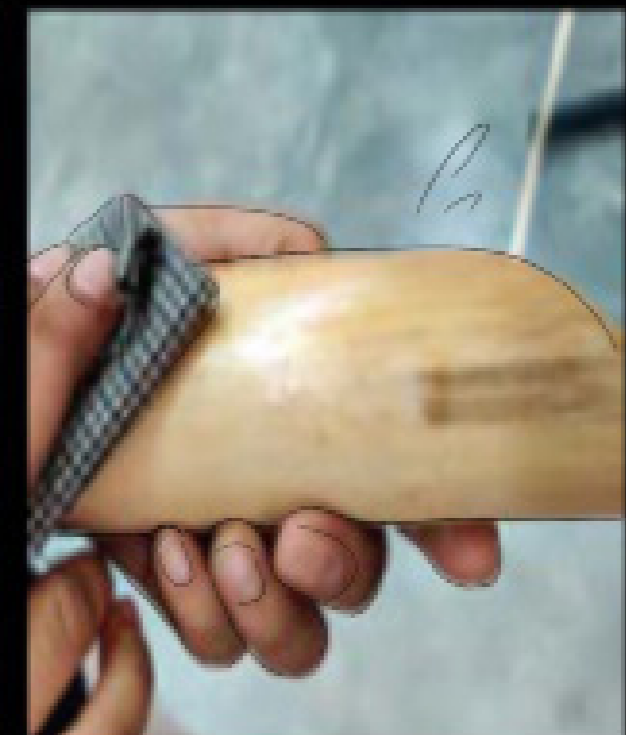

Oiling

Isometric View

TECHNICAL SPECIFICATION

Material - Bamboo
Sand
Finish - Lacquer

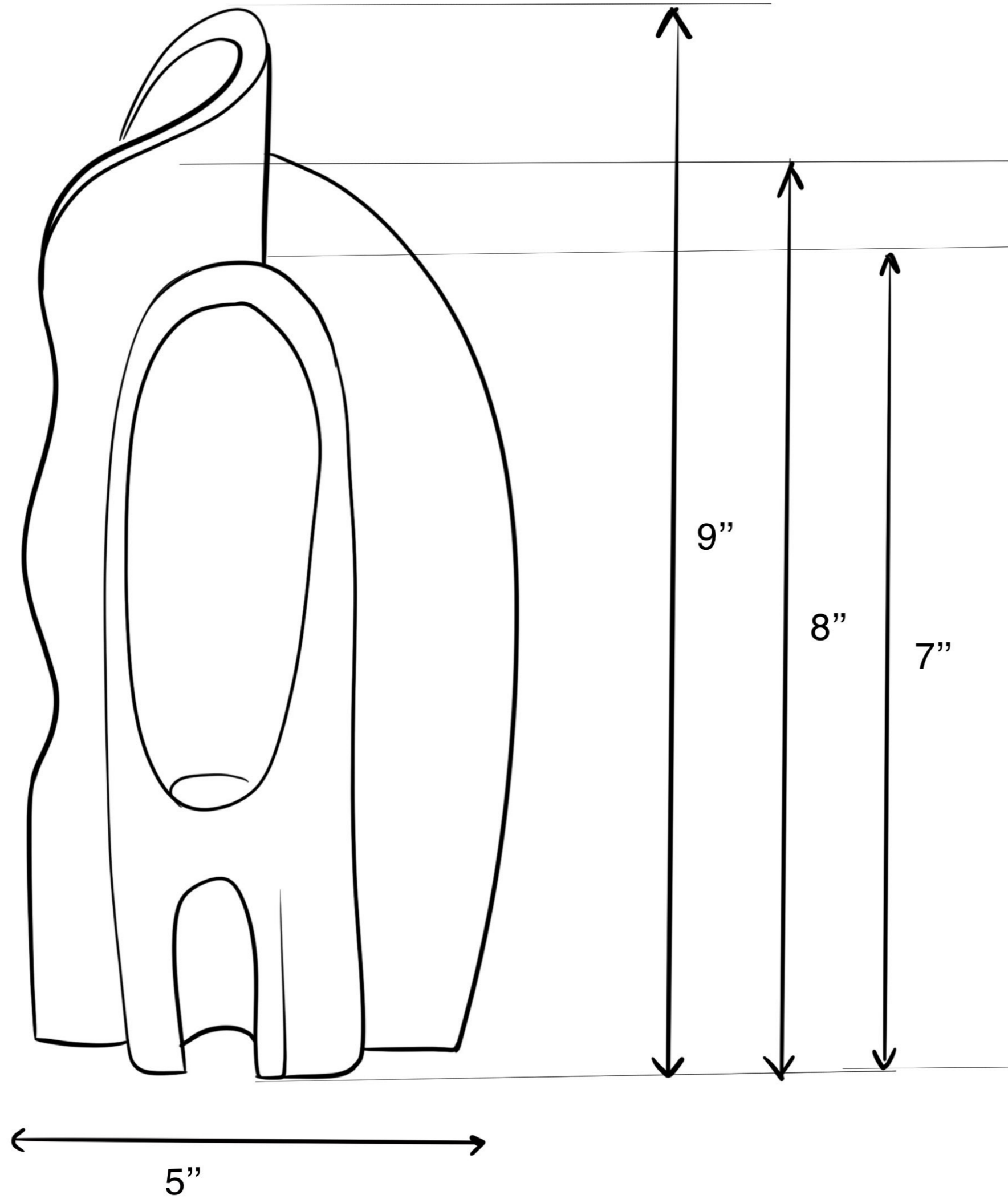

Side-1

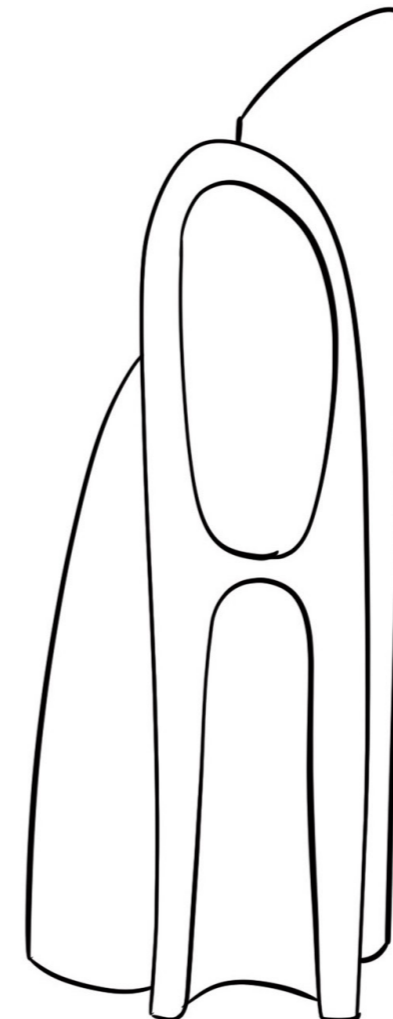

Side-2

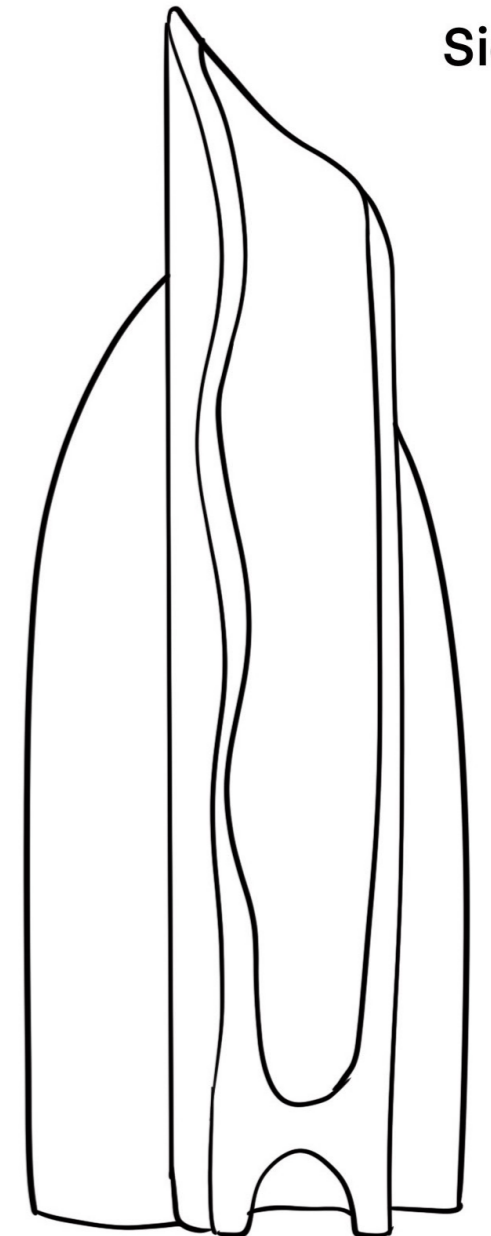



Arunima Sachan / Bamboo Radiance / Only naturals

01 C

TEA LIGHT CANDLE HOLDER

A holder that is specifically designed to house tea lights. Partly clear walls to allow light to pass through. Maintaining the form family, some variations were explored in terms of sharp and smooth curves and height of the structure. Giving a reflective surface finish to the interior wall of bamboo adds to the aesthetic value and amplifies luminosity at the same time.





Both ends cut at different angles.

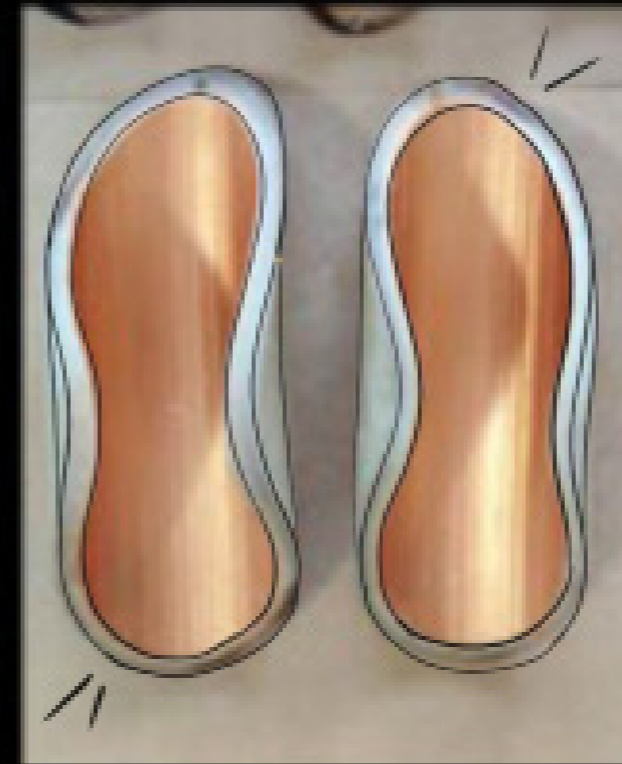

A shiny finish on interior walls.



Joining using araldite

About product :

- A candle holder for a small cozy dinner space.
- Easy portability

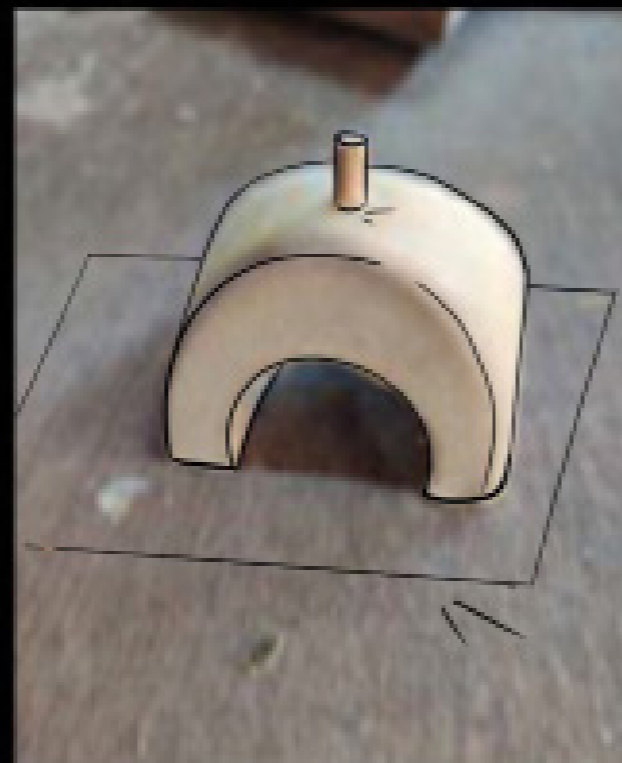

Creating a stable base.

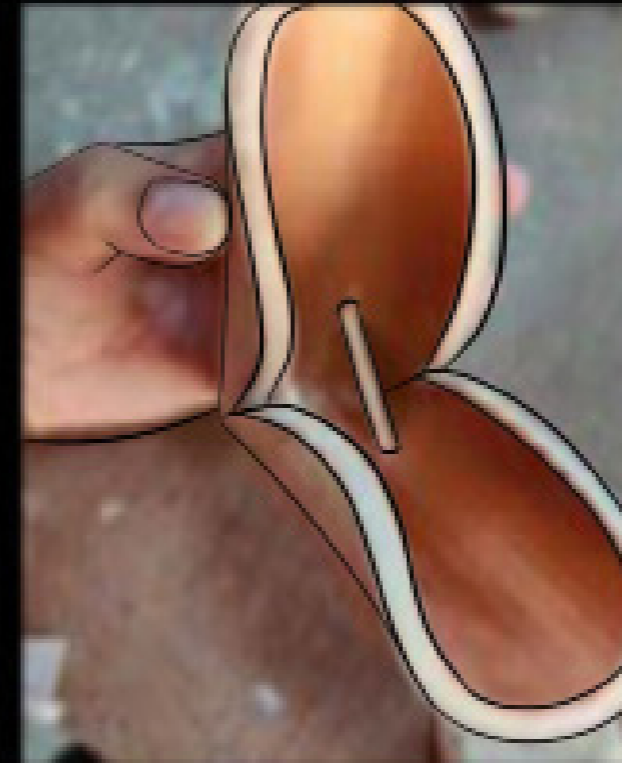

Two parallel dowels to create a platform for candle.

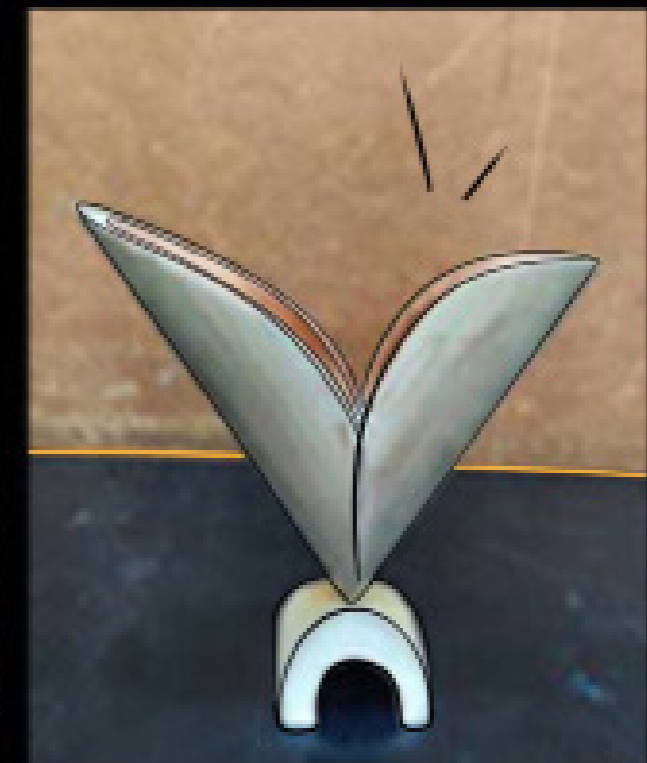

Finishing and Oiling.

Isometric View

TECHNICAL
SPECIFICATION

Material - Bamboo
Finish - Lacquer

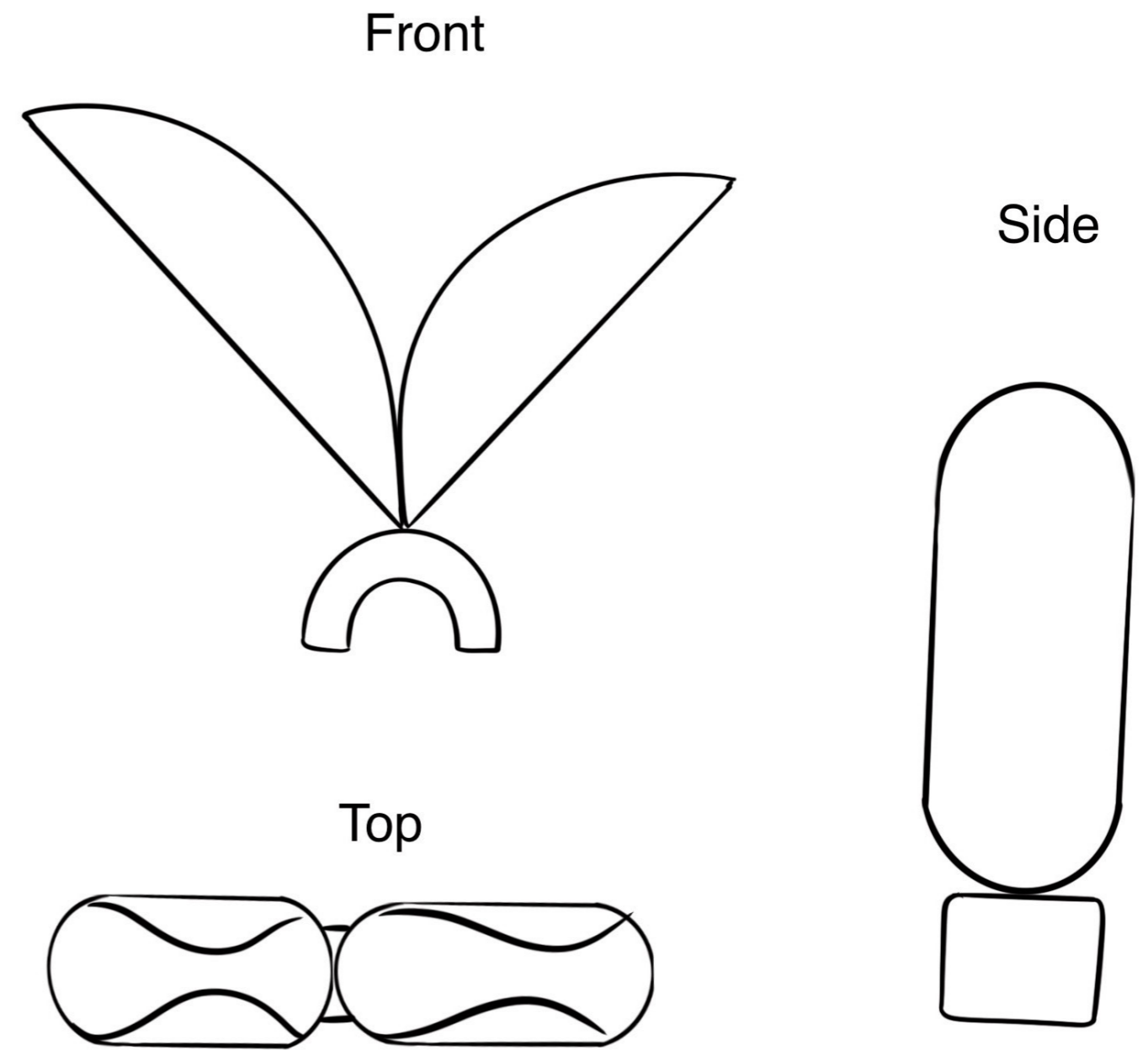
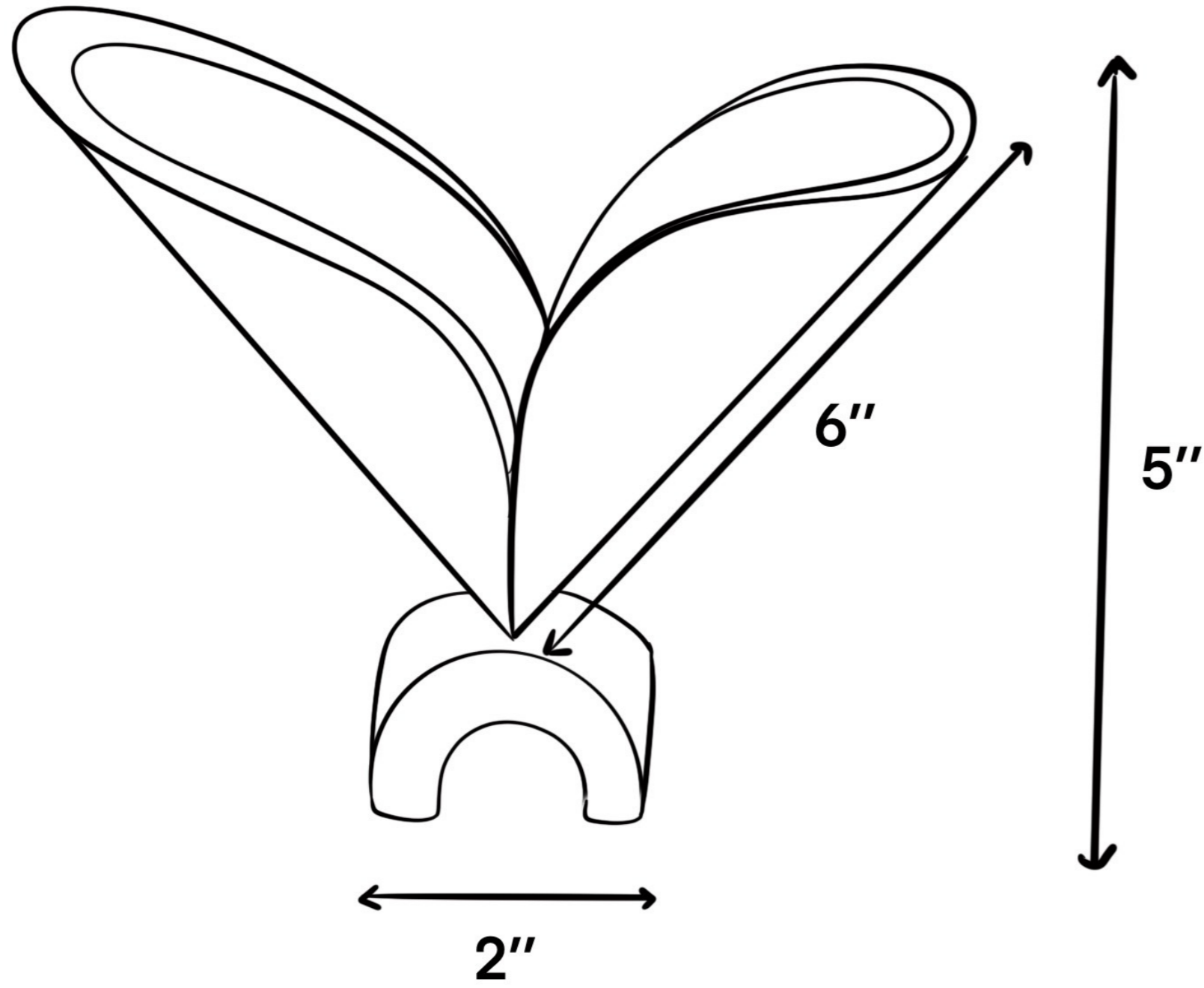

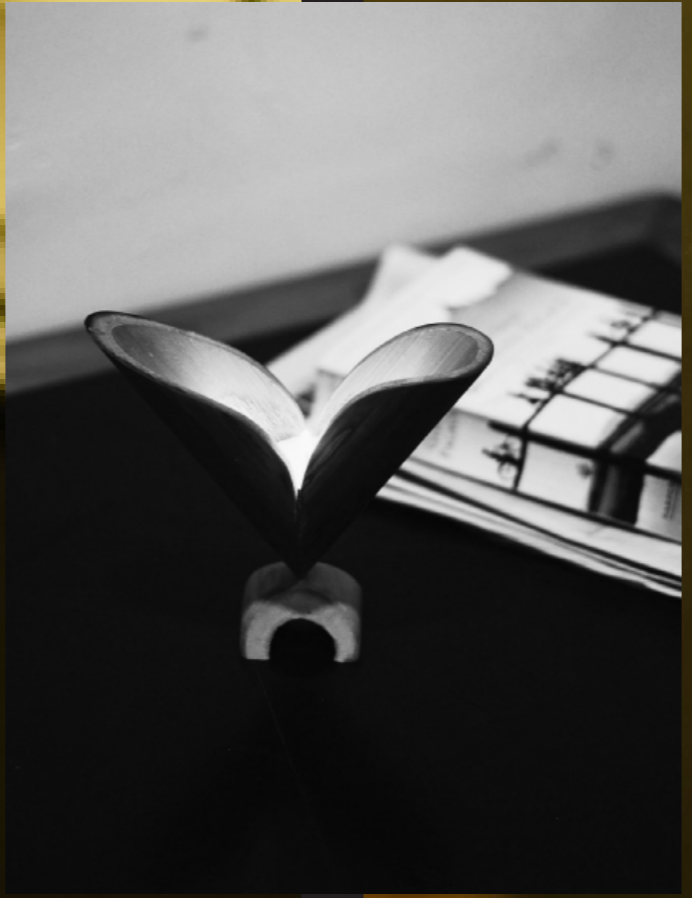

Arunima Sachan / Bamboo Radiance / Only naturals



02
FORM
EXPLORATION

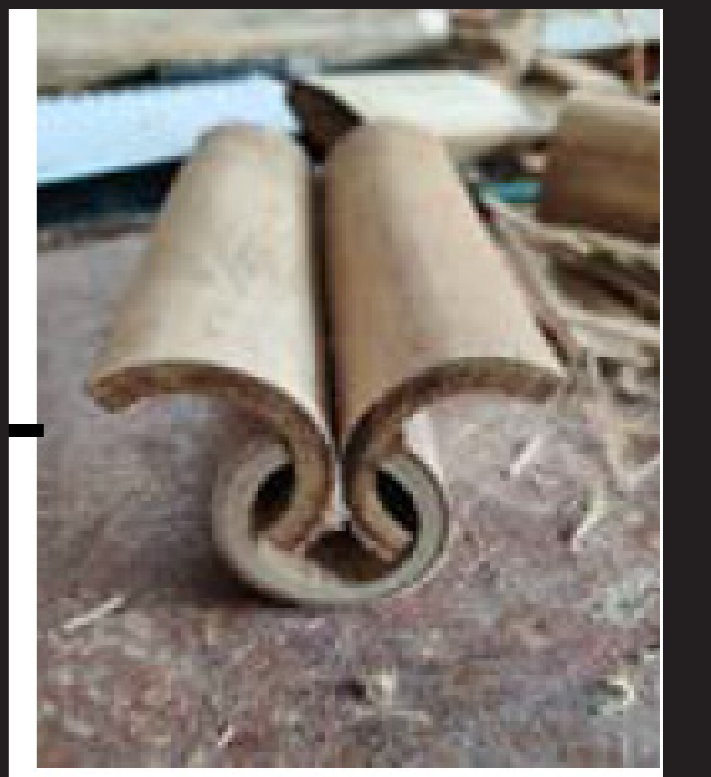



THANK YOU